

# REDUCTION OF SEISMIC RISK THROUGH NON-STRUCTURAL ELEMENTS

KnowRISK PORTFOLIO OF SOLUTIONS

MÓNICA AMARAL FERREIRA

CARLOS SOUSA OLIVEIRA

FRANCISCO MOTA DE SÁ

MÁRIO LOPES

ISABEL PAIS

**KnowRISK Project**

CERIS Technical Guidelines

**CERIS** : Civil Engineering Research  
and Innovation for  
Sustainability

02



# Reduction of seismic risk through non-structural elements.

## KnowRISK portfolio of solutions

### Authors

Mónica Amaral Ferreira, Carlos Sousa Oliveira, Francisco Mota de Sá, Mário Lopes, Isabel Pais  
Instituto Superior Técnico, Universidade de Lisboa

### Technical drawings

Marta Vicente  
Architect, Laboratório Nacional de Engenharia Civil

### Illustration

Hugo O'Neill  
Designer, Instituto Superior Técnico, Universidade de Lisboa

### Scientific Direction

Carlos Sousa Oliveira, Mário Lopes  
Instituto Superior Técnico, Universidade de Lisboa

### Recommended citation

Ferreira, M.A.; Oliveira, C.S.; Mota de Sá, F.; Lopes, M.; Pais, I. (2022) *Reduction of seismic risk through non-structural elements. KnowRISK portfolio of solutions*. CERIS, Lisbon, Portugal. CERIS Technical Guidelines 02-2022.

### Publisher

CERIS - Civil Engineering Research and Innovation for Sustainability  
Instituto Superior Técnico, Avenida Rovisco Pais, 1, 1049-001 Lisboa - Portugal, [ceris@tecnico.ulisboa.pt](mailto:ceris@tecnico.ulisboa.pt)

### Edition

1

### Place and date of publication

Lisbon, 2022

### ISBN

978-989-95625-3-0

### CERIS Code

CERIS Technical Guidelines 02-2022

### Notes

These guidelines in their entirety are protected by copyright. The information contained was compiled to the best of the authors' knowledge and belief in accordance with the principles of good scientific practice. The authors believe that the information in this report is correct, complete and current, but accept no liability for any errors, explicit or implicit. The statements in this document do not necessarily reflect the institutions' opinion.

# Reduction of Seismic Risk Through Non-Structural Elements

KnowRISK Portfolio of solutions



Copyright © 2017

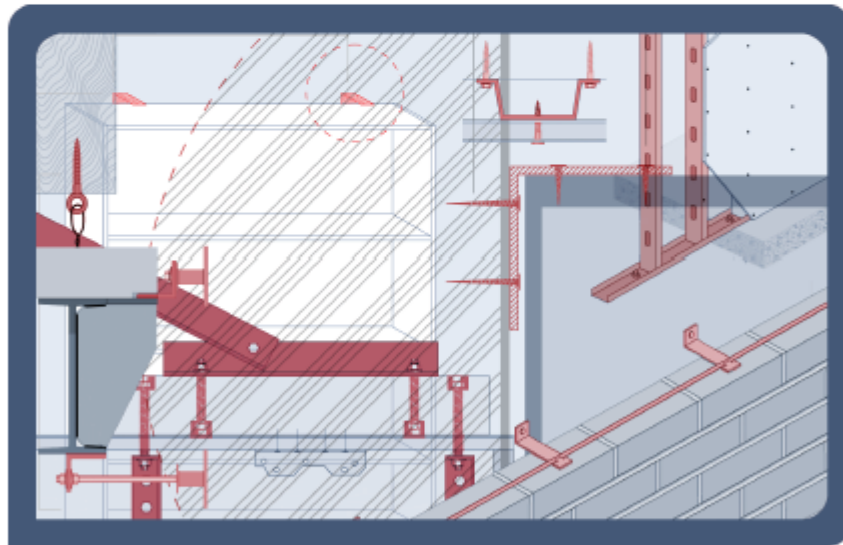

Co-financed by European Commission's Humanitarian Aid and Civil Protection Grant agreement ECHO/SUB/2016/718655/PREV28





## **KNOWRISK PORTFOLIO OF SOLUTIONS**

### **FOR THE REDUCTION OF SEISMIC RISK THROUGH NON-STRUCTURAL ELEMENTS**

**Prepared by the**

**KnowRISK (Know your city, Reduce seismic risk through non-structural elements) Project**

#### *Authors*

**Mónica Amaral Ferreira**, Instituto Superior Técnico, Portugal

**Carlos Sousa Oliveira**, Instituto Superior Técnico, Portugal

**Francisco Mota de Sá**, Instituto Superior Técnico, Portugal

**Mário Lopes**, Instituto Superior Técnico, Portugal

**Isabel Pais**, Instituto Superior Técnico, Portugal

#### *Technical Drawings*

**Marta Vicente**, Architect, Laboratório Nacional de Engenharia Civil

#### *Illustration*

**Hugo O'Neill**, Designer, Instituto Superior Técnico, Portugal

#### *Scientific Direction*

**Carlos Sousa Oliveira**, Instituto Superior Técnico, Portugal

**Mário Lopes**, Instituto Superior Técnico, Portugal

**Version: 1.0 - EN**

**With support from**

**European Commission's Humanitarian Aid and Civil Protection Grant agreement  
ECHO/SUB/2015/718655/PREV28**

**ISBN: 978-989-95625-3-0**

To be cited as:

Ferreira, M.A.; Oliveira, C.S.; Mota de Sá, F.; Lopes, M.; Pais, I. (2018). KnowRISK Portfolio of solutions: for the reduction of seismic risk through non-structural elements.

Under the scientific direction of: Carlos Sousa Oliveira and Mário Lopes  
(available at: [www.knowriskproject.com](http://www.knowriskproject.com))

Any opinions, findings, conclusions, or recommendations expressed herein are those of the authors and do not necessarily reflect the views of EC or the authors' organizations.

## Disclaimer

The effects, descriptions, recommendations, suggestions and solutions included in this document are intended to improve earthquake preparedness; however, they do not guarantee the safety of an individual or of a structure.

## Acknowledgements

This publication was co-financed by the European Commission's Humanitarian Aid and Civil Protection Grant agreement ECHO/SUB/2015/718655/PREV28, with partial support from Instituto Superior Técnico (IST) and Laboratório Nacional de Engenharia Civil (LNEC) from Portugal; Istituto Nazionale di Geofisica e Vulcanologia (Italy) and the Earthquake Engineering Research Centre (EERC) from University of Iceland.

The KnowRISK project gratefully acknowledges the assistance of the following public and private entities for their outstanding contribution of time and expertise, namely CP Combóios de Portugal, CTT Correios de Portugal, EDP - Energias de Portugal, EPAL - Grupo Águas de Portugal, IKEA Portugal, Infraestruturas de Portugal, Jerónimo Martins, Metropolitano de Lisboa, NOS communications and entertainment group, PT-Altice, Siemens, and SONAE MC. The earthquake field missions which took place during the course of KnowRISK, were also helpful and essential to the authors for the study of the causes of non-structural damage.

Some works were especially useful in the production of this publication:

- Reducing the risks of non-structural earthquake damage: A Practical Guide [10];
- Earthquake Hazards in California Schools or the Guidelines for the seismic upgrading of stone-masonry structures.

## **About the KnowRISK Project**

KnowRISK (Know your city, Reduce seismic risk through non-structural elements) is a European Project that aims to facilitate local communities' access to expert knowledge on non-structural seismic risk protection solutions. Scientific knowledge is turned into practical knowledge to be used by citizen and to engage communities in disaster risk reduction (DRR).

KnowRISK is co-financed by European Commission's Humanitarian Aid and Civil Protection Grant agreement ECHO/SUB/2015/718655/PREV28.

Visit [www.knowriskproject](http://www.knowriskproject) for more information.

*March 2018*

# **Contents**

## **1. Scope and objectives**

### **Part I. The non-structural elements**

#### **2. Non-structural elements and causes of non-structural damages**

2.1 Seismic Hazards

2.2 Civil Protection and Forecasts

2.3 Risk factors

2.4 Reduction of seismic risk

2.5 Non-structural elements and damage

#### **3. Dynamic behaviour of buildings**

### **Part II. Solutions to reduce seismic risk**

#### **4. Preventive measures to reduce seismic risk**

4.1 Description of the Portfolio

4.2 List of non-structural elements

4.3 Technical solutions to reduce seismic risk through non-structural elements

#### **5. Selected bibliography**



## 1. Scope and objectives

The KnowRISK Portfolio of Solutions aims to alert building owners and occupants, engineers, designers, architects and other parties to the need to prevent poor performance of non-structural elements in earthquakes. It is important that architects and other parties collaborate and seek specialist engineering advice for seismic restraints and detailing associated with building fit-outs, particularly when a structural engineer is not directly involved with the details of the design. KnowRISK Portfolio of Solutions will help structural engineers, architects and MEP (mechanical, electrical and plumbing) engineers know which of their elements require design and seismic restraint.

Damage to non-structural elements (NSE) constitutes a large portion of loss due to earthquakes, and the loss attains 65% to 85% of total construction cost of commercial buildings [19]. In recent earthquakes in countries having codified seismic design provisions, losses from damage to non-structural elements has far exceeded losses from structural damage [11]. Understanding damages to non-structural elements, sources of non-structural earthquake damage, and how damages affect the functionality of facilities are all critical aspects for developing general recommendations concerning disaster risk management.

The KnowRISK Portfolio of Solutions is a comprehensive publication which identifies potential earthquake hazards associated with non-structural elements of residential buildings, workplaces or schools and further provides detailed instructions (sketches of many simple, practical details for a range of common items) and guidelines for mitigating those hazards, considering the stakeholder groups perspective. Different stakeholder groups usually have different motivations and criteria (e.g., investment risk, operational risks, and market risks) for decisions relative to catastrophic hazard mitigation. The KnowRISK Portfolio of Solutions chooses two groups of stakeholders: (i) "Owners and Facility Managers" and (ii) "Homeowners".

Paragraphs marked FEMA 445 are transcribed directly from FEMA 445 [40].

### Owners and Facility Managers



FEMA 445: Owners and managers are responsible for commissioning building design and construction, acquiring, maintaining and/or operating buildings and facilities. They make decisions about catastrophic risks that lead to action (or inaction) on a relatively narrow scale. Motivations generally spring from the best interests of the specific business or institution. Within the owner/manager category, three perspectives have been identified as important for interaction: investors, institutions and industry. The owners and facility managers are responsible for enabling efficient and effective use of buildings.



### Homeowners

Homeowners are responsible for repairing structural and non-structural elements. This Portfolio is developed by listing non-structural elements that could have potential seismic risk and actions to mitigate that risk on the part of homeowners and tenants.

The recommendations contained in this Portfolio are intended to reduce the threats and potential hazards to people and property but not completely eliminate them.

This Portfolio contains a highly selective list of non-structural elements and is intended as a general description of certain type of services available to qualified customers and homeowners.

All the technical solutions are the result of an extensive research and compilation of relevant safety standards performed by KnowRISK team, from several studies [6, 7], guides, reports, periodicals, and other sources dealing with reduction of seismic risk through non-structural elements.

#### A Final Note

The present Working Document is a first compilation of solutions of a collection of non-structural elements (NSE) deemed to be of more critical importance in the context of reducing the risks of NSE. Further editions of this publication will be more complete both in the number of NSE and in proposed solutions.

## **Part I**

# **THE NON-STRUCTURAL ELEMENTS**

## 2. Non-structural elements and causes of non-structural damages

### 2.1 Seismic Hazards

The seismic hazard in a given region or geographic location is related both to the severity of ground shaking expected in the area and to the likelihood, or probability, that a given level of shaking will occur.

Seismic hazard is often characterized in terms of three levels of shaking intensity: namely low, moderate, and severe. The seismic hazard maps presented in Figure 1 show the geographic areas in Europe with low, moderate, and high probabilities of earthquake ground shaking in the future.

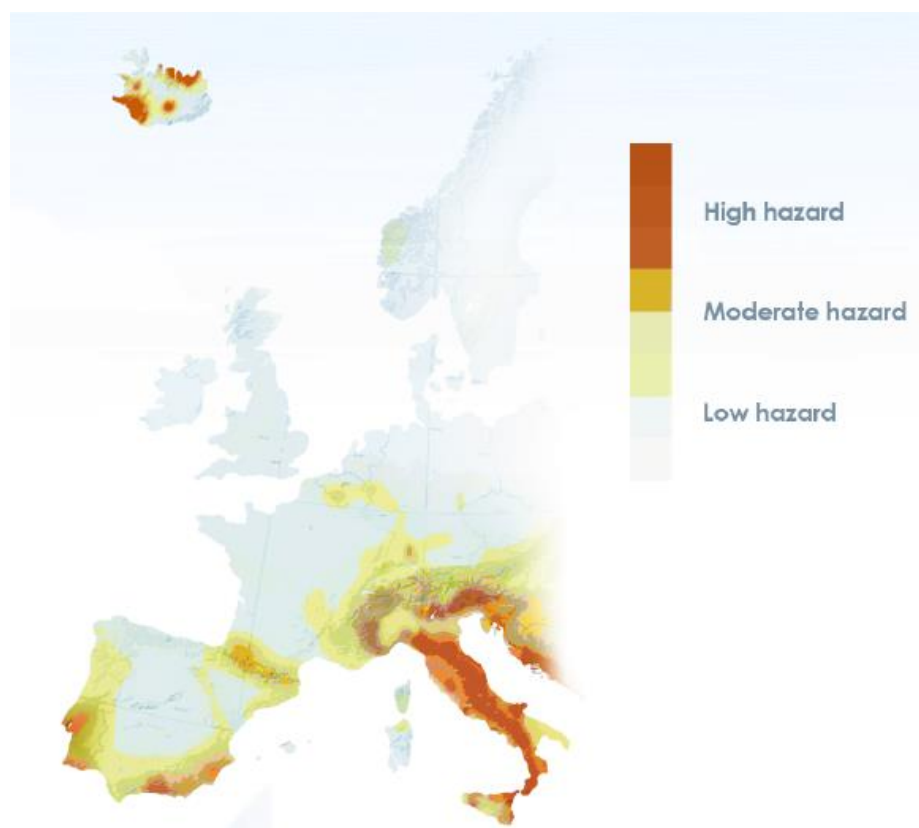

Figure 1 – Seismic hazard in Europe

Source: European Seismological Commission (SHARE, 2003 [41])

### 2.2 Civil Protection and Forecasts

Earthquakes are unpredictable phenomena. The places where it is likely that strong earthquakes happen in the future are known, but not the dates. Therefore the minimization of the effects of earthquakes has to be done without knowing the dates in which they will occur.

The Civil Protection cannot avoid most of the consequences of earthquakes, as it acts essentially after the Emergency is declared (after the earthquake, helping the survivors and all the recovery process) and most of the victims and damage are caused during the earthquake shaking.

It can be concluded from the above that prevention is the main type of action to reduce earthquake effects. Civil Protection is a complement of preventive policies, but cannot replace them.

### 2.3 Risk factors

Seismic risk can be considered the product of three factors:

- **Hazard:** the likelihood that a given zone is hit by earthquakes of certain characteristics during certain periods of time.
- **Exposure:** people and economic assets in a given zone that are exposed to potential earthquakes
- **Vulnerability:** potential for the buildings and all other structures and infrastructures of a given zone to be damaged by earthquakes and consequently endangering people, meaning that inhabitants may be wounded or killed by damaged structures or falling objects. The vulnerability depends on the level of resistance, to earthquake actions, of the buildings and other structures. Vulnerability related to non-structural elements is also very important (see section 2.5) and the main topic of the present document.

To study the impact of earthquakes in a community a fourth factor should be added: **Resilience**, which measures the capacity of the community to deal with the suffered losses.

### 2.4 Reduction of seismic risk

Man cannot act upon the first factor, as earthquakes are geological phenomena that man cannot influence. The capacity to act upon the second factor is very limited. The only factor that depends essentially on human action is the third. It is by reducing the vulnerability by adequate preventive measures that earthquakes risk can be strongly reduced.

Earthquake risk can be associated both to the structures as well as to non-structural elements. Essentially structure transfer loads from one place to another. For instances beams, columns, stairs, foundations and slabs of a building are structural elements. These type of elements are shown in Figure 2.

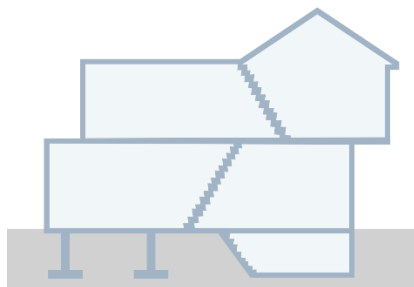

Columns, beams, floor and roof slabs (decking/sheathing), chimney (> 6 m), foundation, shear walls

Figure 2 – Structural elements

Non-structural elements are those which are attached to or housed in a building or building system, but are not part of the main load-resisting structural system of the building.

As examples of non-structural elements are hollow brick partition walls, building contents and plumbing and pipes. Figure 3 shows several non-structural elements.

Structural Elements		
<p>The figure consists of three cross-sectional diagrams of a building. The top diagram shows architectural elements like walls, ceilings, and floors. The middle diagram shows building contents such as furniture, equipment, and storage. The bottom diagram shows mechanical, electrical, and plumbing (MEP) systems like pipes, ducts, and electrical conduits.</p>	Architectural elements	partitions, ceilings, storefronts, glazing, cladding, veneers, chimney (< 6m), and architectural ornamentation, stairways
	Building contents	Furniture, Fixtures and Equipment, such as shelving and book cases, industrial storage racks, retail merchandise, books, medical records, computers and desktop equipment, wall and ceiling mounted TVs and monitors, file cabinets, kitchen, machine shop or other specialty equipment, industrial chemicals or hazardous materials, museum artifacts, and collectibles
	Mechanical, electrical, and plumbing (MEP) elements	pumps, chillers, fans, air handling units, motor control centers, distribution panels, transformers, and distribution systems including piping, ductwork and conduit
	Exterior elements	Fences

Figure 3 – Non-structural elements

If buildings collapse nothing else matters as non-structural elements are also damaged and people are killed. Therefore, structural integrity is the most important issue. However, most earthquakes, especially in developed countries, kill a small part of the population but cause tremendous economic damage, as most buildings don't collapse but many are damaged. They also cause larger numbers of wounded people due to those damages. Most of the cost of the repair of damaged buildings refers to non-structural components, which accounts for more than 70% of the cost of the buildings. This value tends to be higher if the contents are very valuable. Damage to non-structural elements may also be of extreme importance in the cases in which it gives rise to the release of hazardous materials. The damage due to the Nuclear power plant of Fukushima is probably the most well-known case.

## 2.5 Non-structural elements and damage

Non-structural elements are divided into three main categories:

- Building content

- Architectural: exterior and interior elements
- Mechanical, Electrical and Plumbing (MEP) elements

Non-structural damage excludes damage to the building structure. Such damage occurs frequently even under moderate intensities of earthquakes as follows:

- i) Cracking and overturning of masonry parapets, roof chimneys, large cantilever cornices and balconies.
- ii) Falling of plaster from walls and ceiling particularly where it was loose.
- iii) Cracking and overturning of partition walls, infill walls and cladding walls from the inside of frames.
- iv) Cracking and falling of ceilings.
- v) Cracking of glass panes.
- vi) Falling of loosely placed objects, overturning of cupboards, etc.

### 3. Dynamic behaviour of buildings

Most of this Section was transcribed from FEMA, 2012. "There are many factors affecting the performance of non-structural elements during an earthquake and the extent to which they will sustain damage. Specifically, there are four principal causes of damage to non-structural elements [6], namely:

#### *Inertial forces*

When a building shakes during an earthquake, the base of the building typically moves with the ground. The entire building and its contents above the base experience inertial forces that push them back and forth in a direction opposite to the base excitation. When unrestrained or marginally restrained items are shaken during an earthquake, inertial forces may cause them to slide, rock, or overturn (e.g. Figure 4). For example, file cabinets, emergency generators, suspended items, freestanding bookshelves, office equipment, and items stored on shelves or racks can all be damaged as they move and interact with other items, fall, overturn or become disconnected from attached components. The shaking can also cause damage to internal components of equipment without any visible damage or movement from its original location.

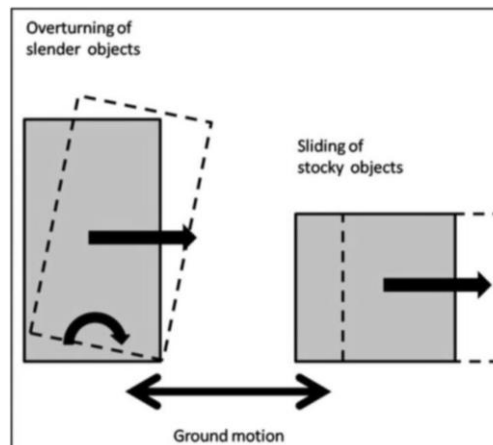

Figure 4. Sliding and overturning due to inertial forces [6].

#### *Building deformations*

During an earthquake, structural components of buildings can deform, bend or stretch and compress in response to earthquake forces. When the building deforms, the columns or walls deform, as represented in Figure 5, and any windows or partitions rigidly attached to the structure must also deform or displace by the same amount. Brittle materials such as glass, plaster partitions, and masonry infill or veneer cannot tolerate any significant deformation and will crack. Once cracked, the inertial forces in the out-of-plane direction can cause portions of these architectural components to become dislodged and to fall far from their original location, possibly injuring passers-by underneath them.

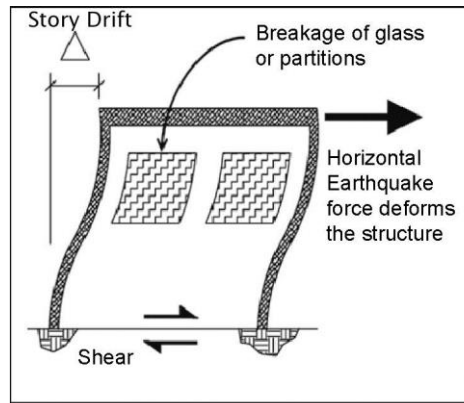

Figure 5. Non-structural damage due to building deformation [6].

*Building separations or pounding effects*

Pounding of adjacent buildings or movement across separation or expansion joints (the distance between two different building structures, as shown in Figure 6) can be a serious hazard in seismically active areas.

To provide functional continuity between adjacent structures or between structurally independent portions of a building, utilities must often extend across these building joints, and architectural finishes must be detailed to terminate on either side. The separation joint may be only 2.5 cm or 5 cm wide in older construction or 30 cm or more in some newer buildings, depending on the expected horizontal movement, or seismic drift between buildings. Flashing, piping, conduit, fire sprinkler lines, heating, ventilation, and air-conditioning (HVAC) ducts, partitions, and flooring all have to be detailed to accommodate the seismic movement expected at these locations when the two structures move closer together or further apart. Damage to items crossing seismic separation or expansion joints is a common type of earthquake damage. If the size of the gap is insufficient, pounding between adjacent structures may result, which can damage structural components but more often causes damage to non-structural elements, such as parapets, veneer, or cornices on the façades of older buildings.

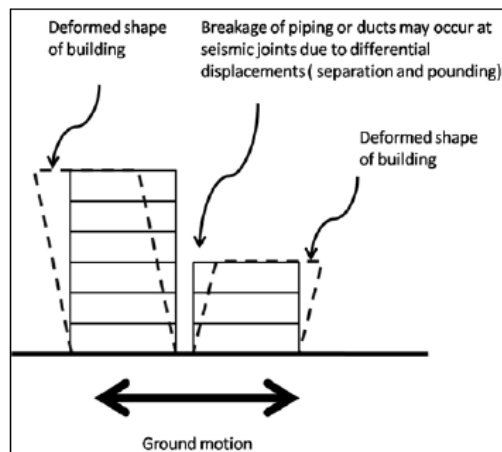

Figure 6. Non-structural damage due to separation and pounding [6].

### *Interaction between adjacent non-structural elements*

Interaction between adjacent non-structural systems which move differently from one another cause non-structural damage.

Many non-structural elements may share the same space in a ceiling plenum or pipe chase; these items may have different shapes, sizes, and dynamic characteristics, as well as different bracing requirements. Some examples of damaging non-structural interactions include:

- i) Sprinkler distribution lines interact with the ceiling causing the sprinkler heads to break and leak water into the room below.
- ii) Adjacent pipes of differing shapes or sizes are unbraced and collide with one another or adjacent objects.
- iii) Suspended mechanical equipment swings and impacts a window, louver, or partition.
- iv) Ceiling components or equipment can fall, slide, or overturn blocking emergency exits.”

The building contents, as usually are elements supported only at the base, is more sensitive to the horizontal accelerations, which tend to be higher in the upper floors. Furthermore, an amplification factor may take place due to proximity of periods of vibration of the building and of the element in study.

The architectonic elements, especially partition walls, tend more sensitive to interstorey drifts, as they are supported in the structural elements. These tend to be higher on the lower or intermediate floors, depending on the structural type of the building (moment resisting frames or shear walls). Other architectonic elements, such as decorative objects, are more sensitive to horizontal accelerations.

The Mechanical, Electrical and Plumbing (MEP) elements can be sensitive to accelerations, to inter-storey drifts, or both. For instances electrical or mechanical equipment lying on the buildings floor may overturn due to the accelerations on the floors. Even if they don't overturn, they may suffer interior damage due to the accelerations acting upon their components. Other MEP may be more sensitive to building deformations: that is the case of pipes embedded in the structure, due to the deformations the structure will impose on them.

## **Part II**

# **SOLUTIONS TO REDUCE SEISMIC RISK**

## 4. Preventive measures to reduce seismic risk

The purpose of this Portfolio is to establish the minimum requirements to safeguard the public health, through understandable design examples and actual solutions to significantly reduce damage to a building by fixing a number of known and common weaknesses.

These seismic restrains requirements can apply to almost any building regardless of occupancy type, particularly buildings relied on to provide essential services in the event of a disaster..

This Portfolio of Solutions describes the most common weaknesses that can result in a building being damaged by earthquakes. It enables owners to make a check-list of non-structural elements and identify their weaknesses. It also allows building systems designers, who don't have a detailed knowledge of seismic engineering to use a range of ready-made solutions for commonly used components, adapt them to a particular project and verify the suitability of solutions by engaging a seismic specialist.

Common non-structural mitigation techniques are presented below [9]:

1. *Brace Exterior Elements* – Reduce or eliminate damage to exterior elements by bracing parapets, anchoring or replacing cornices and architectural elements, bracing chimneys, securing wall panel anchors, bracing large windows, or replacing window glass.
2. *Anchor Interior Elements* – Anchor interior non-structural elements (non-load bearing interior walls, partition walls, suspended ceilings, and raised computer floors) by securing of un-braced suspended (drop) ceilings and overhead lighting fixtures with wires and struts, bracing of interior partitions, and anchoring raised computer floors at their pedestal supports.
3. *Protect Building Electrical, Mechanical, and Plumbing Systems* –Heavy building utility equipment can be anchored by protecting springs on vibration isolators, securing gas tanks with metal straps, and bracing and restraining elevator counterweights and rails. Utility connections and supply lines can be secured by bracing overhead utility pipes and HVAC ducts with metal brackets, installing flexible pipes or conduits at connections, and installing seismic shutoff valves on gas lines.
4. *Secure Building Contents* – Secure furnishings and other building contents to reduce movement from earthquake-induced ground shaking. Desktop computers and equipment can be restrained with chains, cables, clips, or cords. Metal anchors can be used to secure bookcases and large filing systems to floors, walls, or each other. Hazardous materials and other miscellaneous furnishings (tables, chairs, cubicle wall partitions, wall hangings, etc.) can be secured with straps, anchors, angle brackets, and sturdy hooks.

## 4.1 Description of the Portfolio

KnowRISK Portfolio of Solutions is a comprehensive publication which identifies potential earthquake hazards associated with non-structural elements of residential buildings, workplaces or schools and further provides detailed instructions (sketches of many simple, practical details for a range of common items) and guidelines for mitigating those hazards, considering the stakeholder groups perspective.

However, it should be emphasized that non-structural seismic hazard mitigation solutions can only be effective if the building itself is relatively damage resistant during earthquakes. If a building, however important to the community, is highly vulnerable to significant damage or collapse in earthquakes, undertaking non-structural mitigation solutions for the building will most likely not be viable or cost-effective. Bolting a bookcase to the wall, for example, is not worthwhile if the building collapses.

Different stakeholder groups characteristically have different motivations and criteria (e.g., investment risk, operational risks, and market risks) for decisions relative to catastrophic hazard mitigation. The KnowRISK Portfolio of Solutions chooses two groups of stakeholders: "Owners and Facility Managers" and "Homeowners".

"Owners and Facility Managers" have a vision of the non-structural risks, in the perspective of an activity of support and management of spaces, administrative buildings and of operational efficiency through their customer services and contact center operations. Customer expectations are high, and they are less tolerant or patient with companies for dealing with problems. So, a set of in-person interviews to evaluate the stakeholder expectations and to know what information each stakeholder needs were done to help to determine the best way to convey information to each group.

A total of 15-20 stakeholders contributed to this study (Task D2 [14]). After a dedicated meeting made with each stakeholder, they were asked to collaborate, examining a list of main non-structural elements (see Section 4.2), choose which elements are more critical to maintaining production continuity, or hazardous if damaged. Depending on the stakeholder's priorities, high priority buildings can be selected based on occupancy (life safety), critical facilities (life safety and economic impacts), or on value of contents (avoided damage). For solutions such as bracing lightweight elements, such as suspended ceilings, the type of occupant should be considered because the potential injury rates might be greater for small children in a school and for senior citizens in a nursing home. In lifelines that are important for the live of the populations or for the continuity of economic activities, non-structural mitigation solutions are intended to ensure the continued function of critical facilities after earthquakes (secure or reinforce emergency generators for critical facilities, brace critical medical equipment in hospitals, brace critical pumps for potable water systems, and others.

Therefore the stakeholder's feedback was very helpful to balance and refine our approach and it includes the completion of the initial list of elements and the characterization of priorities on individual interventions.

All these analyses are described in detail in the deliverable C4 of the KnowRISK project, available at [https://knowriskproject.com/wp-content/uploads/2017/05/KR\\_Deliverable-C4.pdf](https://knowriskproject.com/wp-content/uploads/2017/05/KR_Deliverable-C4.pdf)

The general page layout for each non-structural element and the preventive measures to reduce seismic risk is an A4-size with the following structure:









- i) Name of non-structural element;**
- ii) Table with a set of icons that provide essential information such as:**

- a) type of stakeholder (Homeowners or Owners and Facility Managers),
- b) importance of the consequences of the potential damage expressed in terms of three types of risk:
  - Life Safety (LS): The risk that people will be struck by a falling object, cut or otherwise injured. Could anyone be hurt by this component in an earthquake?
  - Property Loss (PL): The risk of economic losses to repair or replace damaged items. Could a large property loss result?
  - Functional Loss (FL): The risk that an essential function will be disrupted. Could the loss of this component cause an outage or interruption?
- c) skills needed to implement the proposed solution. The three different types of skills/expertise needed to implement the solution are:
  - Do-It-Yourself (DIY) - these are simple, generic details for non-structural items found in the home, office, classroom, or small business, that can be installed by a handyman using common tools and readily available materials.
  - Non-Engineered (NE)
  - Engineering Required (ER) - these are schematic details that need to be developed by a design professional and will require installation by a specialty contractor. The designation Engineering Required has been used for items where the self-help approach is most likely to be ineffective. Consult a structural engineer for seismic connection and separation details if you are a building services or mechanical engineer responsible for the design of non-structural elements.
- d) Indication of the repair time of the non-structural element;
- e) Indication of technical solution costs.

**iii)** Typical causes of damage;

**iv)** Recommended methods, i.e., technical solutions to reduce seismic risk;

Table below defines the icons used to represent different criteria:

Icon	Definition
	Stakeholder type: Owners and Facility Managers
	Stakeholder type: Homeowners
	Life safety (Low, Medium, High)
	Property loss (Low, Medium, High)
	Functional Loss (Low, Medium, High)
	Repair time (Low, Medium, High)
	Design solutions / expertise (Do-it-Yourself, Non-Engineered, Engineering Required)
	Estimate of costs to strengthen (Low, Medium, High)

The icons are placed at the beginning of the sheet where the user will see them right away. This will help the reader for an easy access of information and help in taking printouts.

#### 4.2 List of main non-structural elements

nº	Components	Life Safety	Property Loss	Functional Loss	Required Intervention	Priority
1	Heavy flat-screen TV and panels monitor walls	H	H	H	ER	H
2	Hazardous materials storage such as chemicals (labs, pharmacies, schools)	H	M	H	DIY	H
3	Large computer equipment, data centres, computer rooms, freezers/refrigerators	M	H	H	ER	H
4	Fire extinguisher and cabinet	M	H	H	DIY	H
5	Piping and overheads ducts	H	H	H	ER	H
6	Tall shelving – typically 150 cm or taller	H	M	M	DIY	H
7	Storage racks and contents	H	M	M	ER	H
8	Tall file or storage cabinets for kitchen and office, and furniture	H	M	M	DIY	H
9	Fluorescent lighting fixtures	H	M	M	NE	H
10	Fragile artwork	L	H	L	DIY	H
11	Suspended ceiling	H	H	H	ER	H
12	Desktop computer equipments, printers, copiers, scanner	L	H	M	DIY	H
13	Canopies	H	H	M	ER	M
14	Masonry Exterior Walls	H	H	H	ER	M
15	Exterior wall components: Adhered veneer	H	H	L	ER	M
16	Exterior wall components: Anchored veneer	H	H	L	ER	M
17	Concrete panels	H	H	H	ER	M
18	Masonry Interior Walls	H	H	H	ER	M
19	Parapets, cornices, corbels and decorative elements	H	H	L	ER	M
20	Stairways	H	M	H	ER	M
21	Compressed gas cylinders / Tanks / Bottles	H	H	L	NE	M
22	Raised access floor	M	H	H	ER	M







n°	Components	Life Safety	Property Loss	Functional Loss	Required Intervention	Priority
23	Interior partitions - plaster	M	H	H	ER	M
24	Telecommunication antennae	M	M	H	ER	M
25	Elevators	M	H	H	ER	M
26	Signs and publicity	H	M	M	ER	M
27	Glazing and windows	H	M	M	NE	M
28	Chimneys	M	M	M	ER	M
29	Roof tiles					
30	Modular partitions	M	M	M	NE	M
31	Emergency power generator	L	M	H	ER	M
32	Solar panels	L	H	M	ER	M
33	Transformers	L	H	H	ER	M
34	Hanging objects	L	L	L	DIY	M
35	Ventilated façade system	H	M	M	ER	M
36	Balconies (masonry buildings)	H	H	M	ER	M
37	Electrical control panels, motor control centres and switchgear	M	M	M	ER	L
38	Batteries and battery racks	L	M	M	ER	L
39	HVAC	L	M	M	ER	L
40	Vases and Flower pots (outside or indoors)	M	L	L	DIY	L

**NOTE:** The elements lighted in gray were not treated in this Working Document and will be analysed in future versions. However, the identification numbering was kept as in Section 4.2.

## **4.2 Technical solutions to reduce seismic risk through non-structural elements**

This section lists a set of most common and relevant non-structural elements and their technical solutions to reduce seismic risk. Knowing which non-structural elements is most important or presents a potential risk to each stakeholder involved in the project, was relevant to identify and define the various solutions suggested.

## 1. Heavy flat-screen TV and panels monitor walls

Stakeholder	Life safety	Property loss	Functional loss
			
Solution/ Expertise	Repair time	Costs of strengthen	
			

### Typical causes of damages





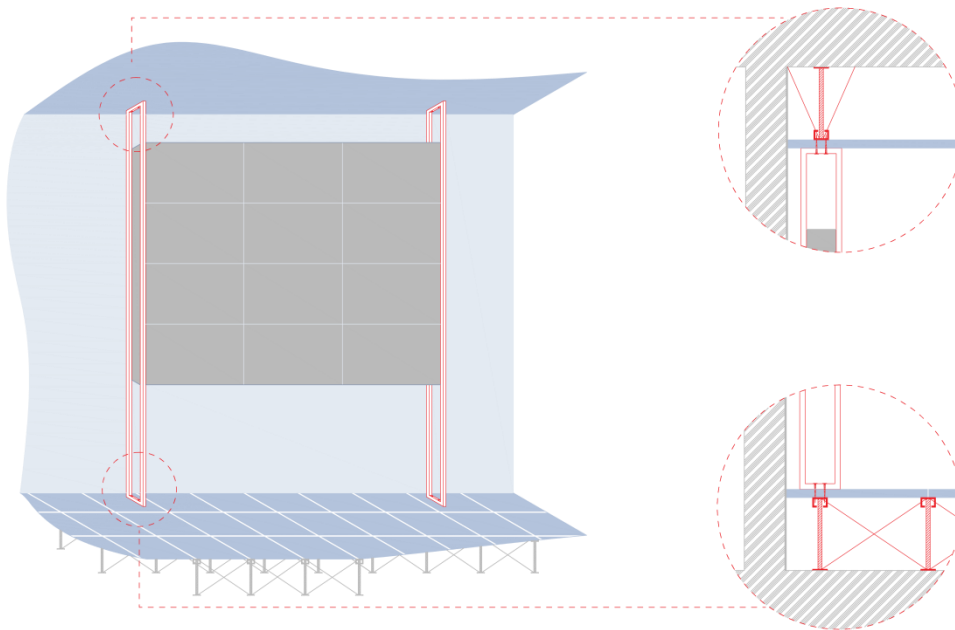

Flat-screen TV's and monitors, especially large ones, could easily topple during an earthquake, causing a range of injuries. Sometimes injuries are severe enough to be fatal.

### Recommended methods

Connect heavy flat-screen and panels monitor walls to the floor and ceiling. Floor slabs and free access floor panels are not connected, so heavy video monitors cannot be secured only to the floor panel. To secure furniture and floor slabs, insert reinforcing materials under floor panels and sandwich the panel using long anchor bolts (see raised access floor).



Technical drawing by M.Vicente

2. Hazardous materials storage such as chemicals (labs, pharmacies, schools)			
Stakeholder	Life safety	Property loss	Functional loss
			
Solution/ Expertise	Repair time	Costs of strengthen	
			

### Typical causes of damages

Unsecured or improperly stored hazardous materials resulting in a release may close businesses located in an otherwise undamaged building. It poses health and safety risks to employees, students, staff and the environment.

### Recommended methods

Anchor all shelving units or cabinets used for storage of hazardous materials to walls using L-brackets.

Chemical storage shelving must have shelf lips or other restraining devices (e.g. lip, wire or bungee cord along edge) or front panel plates and vertical spacers installed to prevent chemicals from falling [27].

Seismic netting holds small, light-weight items [15].





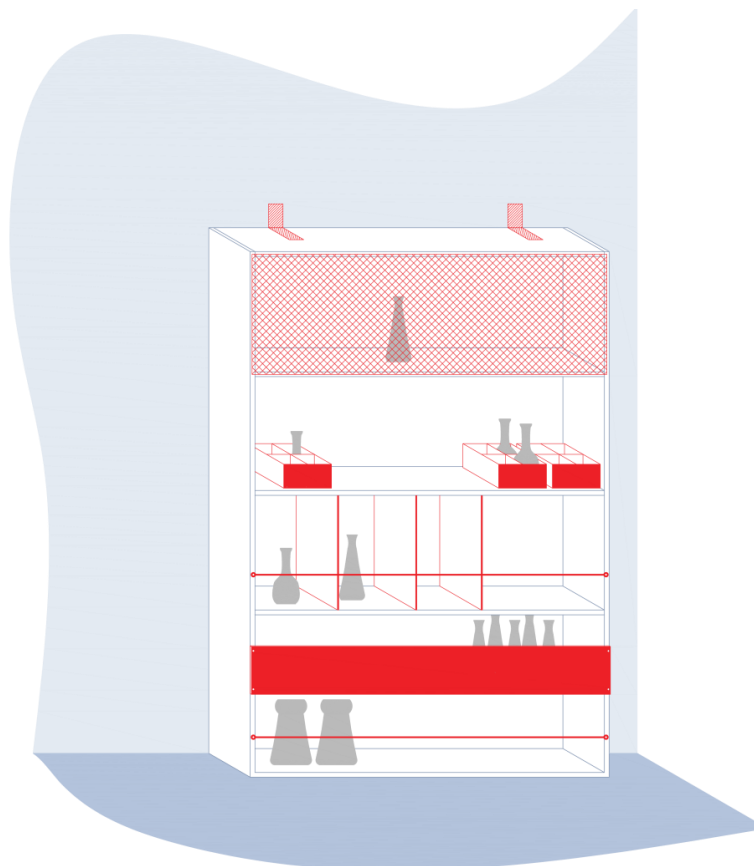

To prevent accidental mixing of chemicals, incompatible materials must be segregated properly, at a safe distance from each other to avoid mixing if the containers fall and break.

Relocate heavy items or volatile chemicals to floor mounted cabinets.



Adapted from [15] by M. Vicente

### 3. Large computer equipment, data centres, computer rooms, freezers/refrigerators

Stakeholder	Life safety	Property loss	Functional loss
			
Solution/ Expertise	Repair time	Costs of strengthen	
			

#### Typical causes of damages

Earthquake damage can be particularly devastating to the floor-mounted equipment's such as industry's data centres or freezers/refrigerators contents in hospitals and laboratories. Going beyond the health and safety of its staff, the loss of uptime resulting from an earthquake can be financially devastating. If a seismic event occurs and the facility is unprotected, the physical damage to servers and IT equipment can also be beyond repair. The combination of loss of equipment and downtime for clients will likely result in the loss of the business in its entirety. Access floors (raised floor) may collapse if not adequately braced and anchored.

#### Recommended methods

One option is bolt the data center equipment racks directly to the floor. With raised floors, racks can be bolted to the substructure (see raised access floor). This will secure the server rack to the substructure, but is less secure as it relies on the subfloor remaining intact during an earthquake. Longer threaded lug bolts can be used to drill through the raised floor directly into the slab, which gives slightly better protection.

Rigid bolting is the absolute minimum level of protection a data center should employ. This method physically protects personnel that are working within a data center during an earthquake as the racks have less risk of falling over on a person. However, the seismic bolt down of racks might not protect IT equipment.

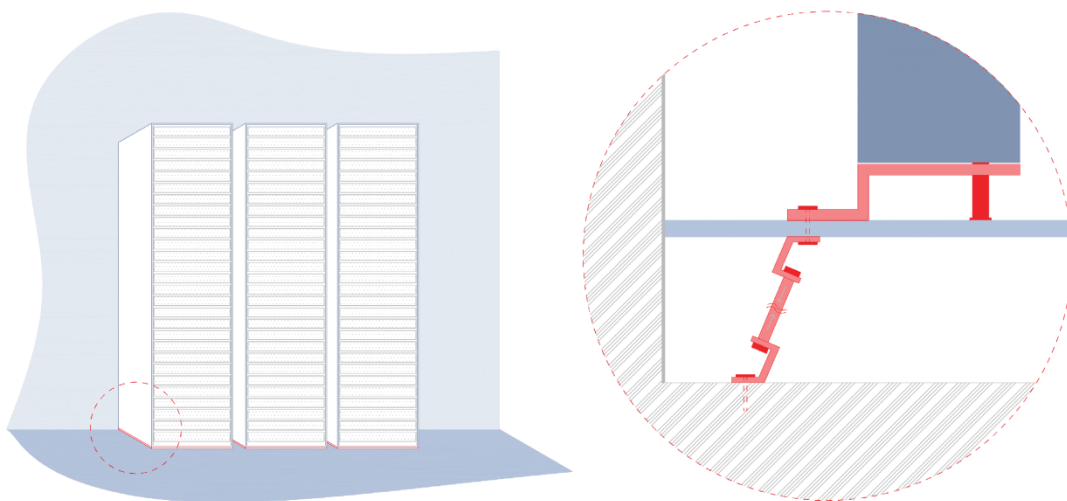





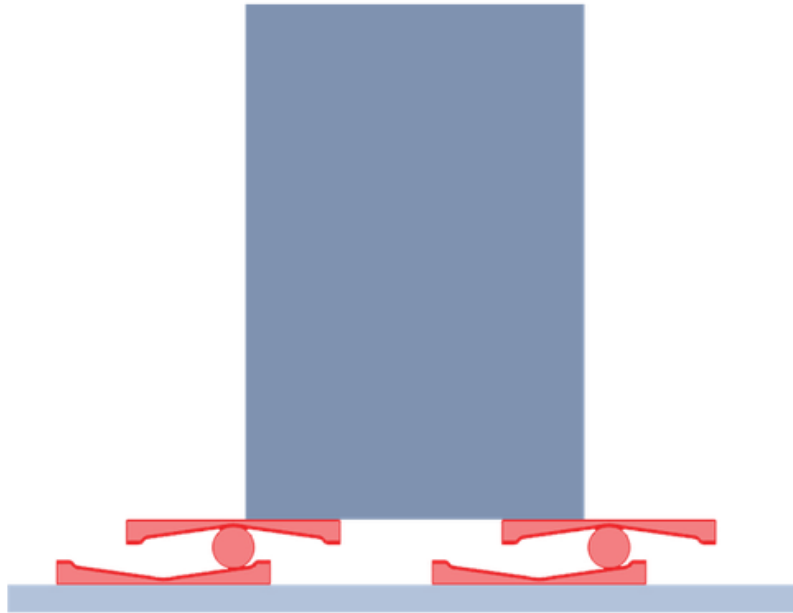

There are other earthquake mitigation options to help protect IT equipment as well as data centre personnel in the event of an earthquake, such as base isolation solutions. Base isolation technology decouples (isolates) the damaging ground vibrations with the substructure during an earthquake.

**Base isolation:**



Adapted from [13] by H. O'Neill

#### 4. Fire extinguisher and cabinet

Stakeholder	Life safety	Property loss	Functional loss
			
Solution/ Expertise	Repair time	Costs of strengthen	
			

#### Typical causes of damages

Unsecured fire extinguisher may fall off wall and damage the shut-off valve or hose, releasing its contents. A damaged fire extinguisher may not be functional in an emergency [12]

#### Recommended methods





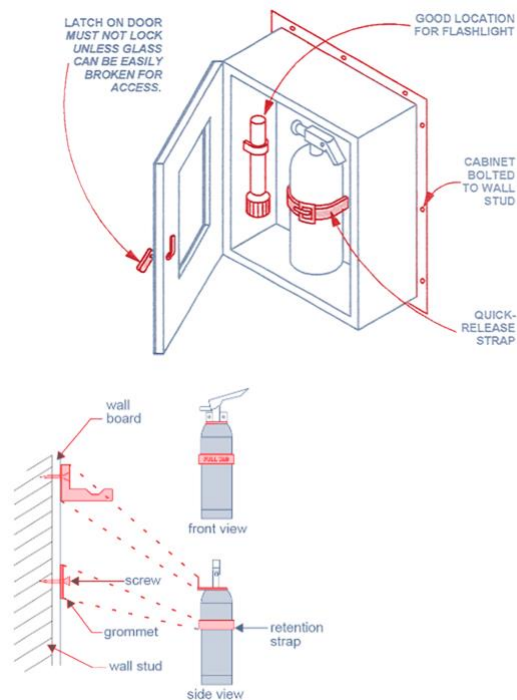

Wall-mounted hardware for fire extinguishers must be secured to wall studs. The fire extinguisher must be secured to the cabinet or bracket.

The cabinet must be accessible either through breakable glass or latched door.



Adapted from [12, 29] by H. O'Neill

## 5. Piping and overheads ducts

Stakeholder	Life safety	Property loss	Functional loss
			
Solution/ Expertise	Repair time	Costs of strengthen	
			

### Typical causes of damages

Some of the main causes of damage to piping and overhead ducts are swaying and impact of unbraced pipes with adjacent piping or structure. Pipes are particularly vulnerable to damage at joints, bends, penetrations through walls or structural members, and connections to equipment. Piping may be damaged as a result of differential movement between points of attachment. Fluids may leak from damaged joints or broken pipe; property losses and business outages are often attributed to fluid leaks from piping.

### Recommended methods

All piping systems must be seismically restrained, unless:

- the pipes have a diameter less than 50 mm;
- the pipework is suspended by individual hangers less than 150 mm long from the top of the pipe to the supporting structure.

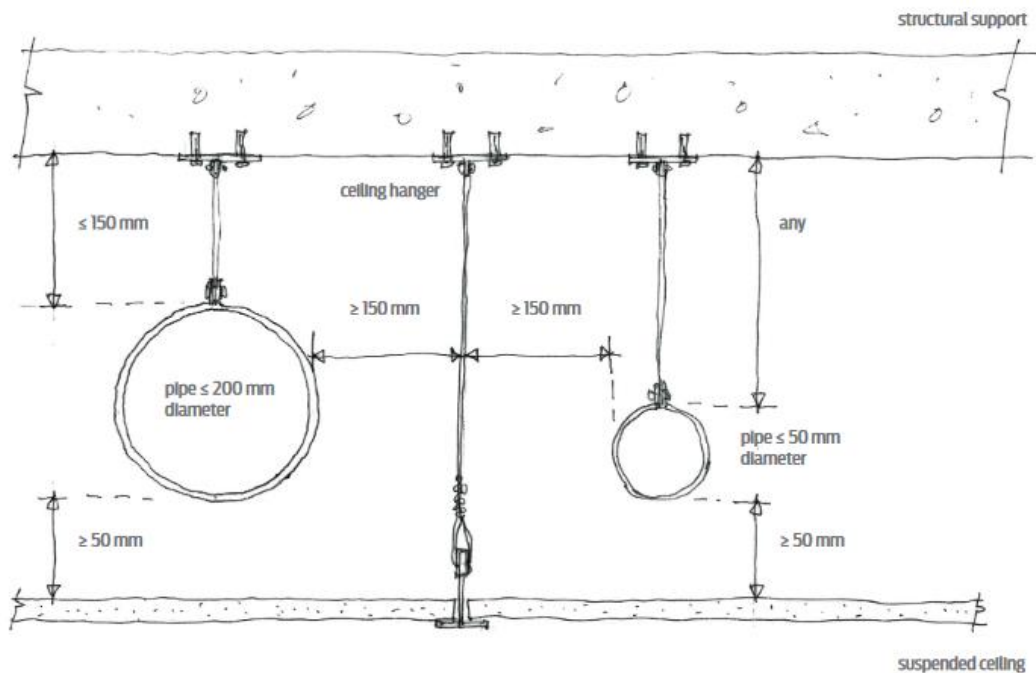

Figure: Where pipe restraints are not required [17].

All piping systems with pipes greater than 200 mm in diameter require specifically designed restraints.

Longitudinal pipe bracing requires the use of a pipe clamp, riser clamp, welded lug or device that provides positive attachment to the pipe and will not slip along the length of the pipe. Longitudinal pipe supports should not rely on friction connections such as U-bolts as these do not provide reliable longitudinal restraint during an earthquake and are likely to slip. Some vendors have items

with names such as “seismic pipe clamp” or “longitudinal restraint device” that are intended for use with longitudinal restraints.

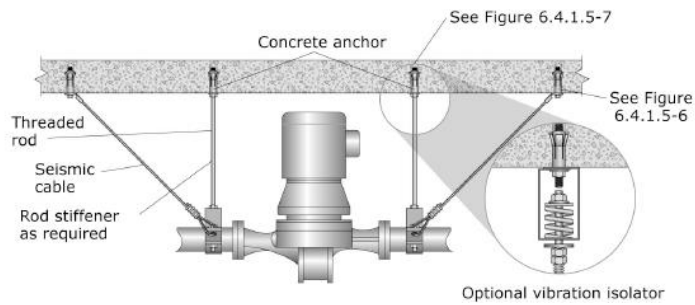
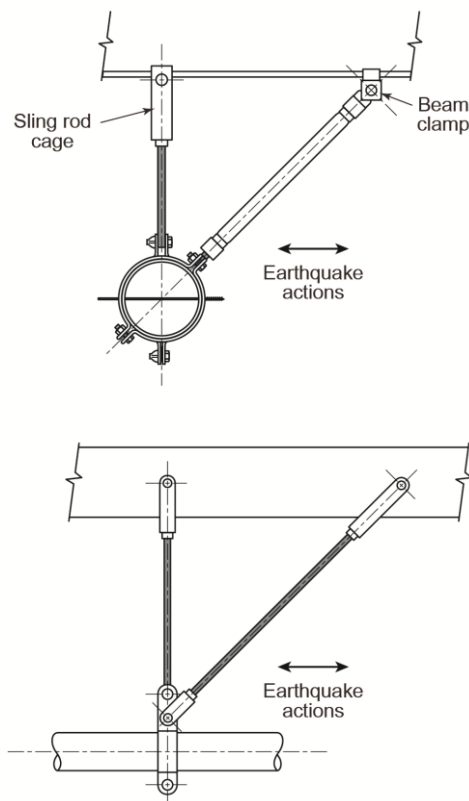

Figure from [6].

Example of transverse (top) and longitudinal (bottom) pipework restraint (from [17]).



Provide adequate clearance (diameter of hole) around piping at wall penetrations. The clearance for firefighting water pipes should be 50 mm larger than the pipe diameter of pipes between 25 mm to 90 mm and 100 mm larger for pipe diameters larger than 100 mm. Note that the filler material between the pipe and the wall should be flexible and fire rated.

Provide flexible connection between piping and equipment, which can accommodate differential movements due to shaking of equipment and piping.







Each unit of equipment connected to a run of piping, conduit or ductwork shall be individually and independently braced [34].



Left: Clearance around piping at wall penetrations. Note the filler material between the pipe and the wall should be flexible and fire rated. Right: Flexible connection between piping and equipment [Photo: 34].

This series of guidebooks, FEMA 412, Installing Seismic Restraints for Mechanical Equipment (FEMA, 2002); FEMA 413, Installing Seismic Restraints for Electrical Equipment (FEMA, 2004c); and FEMA 414, Installing Seismic Restraints for Duct and Pipe (FEMA, 2004d) show installers how to attach mechanical, electrical, and plumbing (MEP) components in a building to minimize potential earthquake damage.

## 6. Tall shelving – typically 150 cm or taller

Stakeholder	Life safety	Property loss	Functional loss
			
Solution/ Expertise	Repair time	Costs of strengthen	
			

### Typical causes of damages

Tall, narrow shelving may tip, slide, overturn or collapse and the contents may spill. Overturned shelving may injure occupants and block doors or exits. Books, files, medical records may fall and get scrambled or damaged. Clean-up and reorganization of spilled items may take many hours or days and result in costly business interruption.

### Recommended methods

Individual bookshelves and filing cabinets should be anchored to a wall (not drywall). Secure the bookcase with metal L brackets and screws along its top or sides (either inside or outside) or with screws through its back.

Screws embedded only in drywall or plaster will pull out. Make sure that all anchoring screws penetrate not just the wall but the studs behind it as well. Regardless of the anchoring method you use, the screws should be long enough to extend at least 5 cm into the wall and studs.

When you cannot secure them to a wall, fasten to the ceiling (ceiling must be strong enough to keep furniture standing) or minimize space between the ceiling and furniture using height-adjustable storage units at tallest setting.

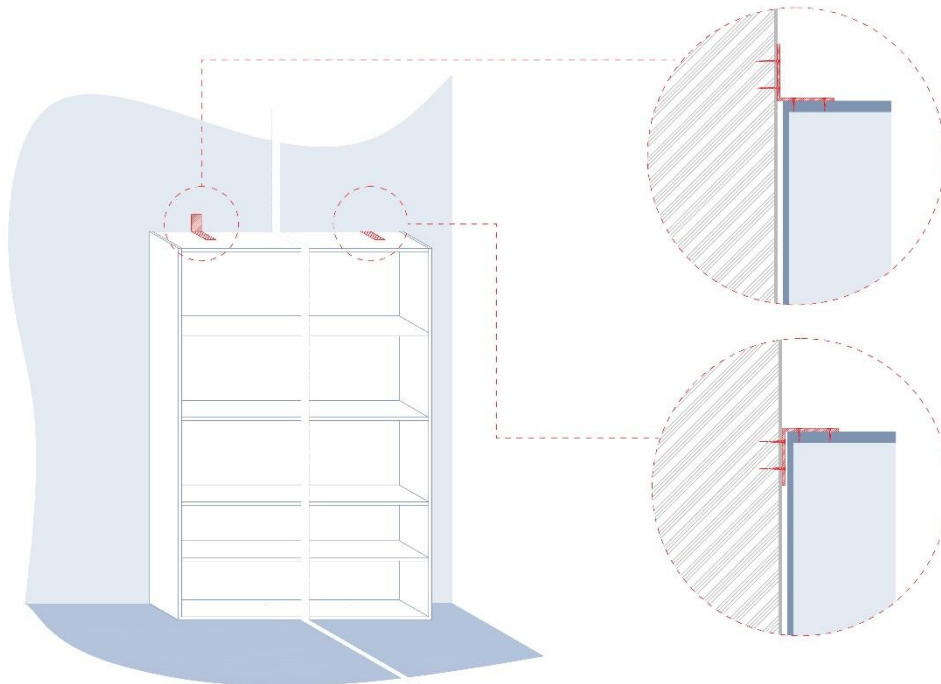

Technical drawing by M. Vicente

Library shelves or file cabinets more than 90 cm in height should either be arranged in groups and fastened together, or secured to an adjacent wall in order to prevent overturning. Connect adjacent shelf units with steel plates. Brace the shelves together and secure them to either the wall, in order to increase their stability and decrease the chance they will be accidentally overturned.

Secure overhead strut with screws to shelving. Overhead bracing strut unnecessary if shelving is internally strong and with good anchor bolts.

Install strap bracing across back of shelving. Provide three screws at each end of the bracing.

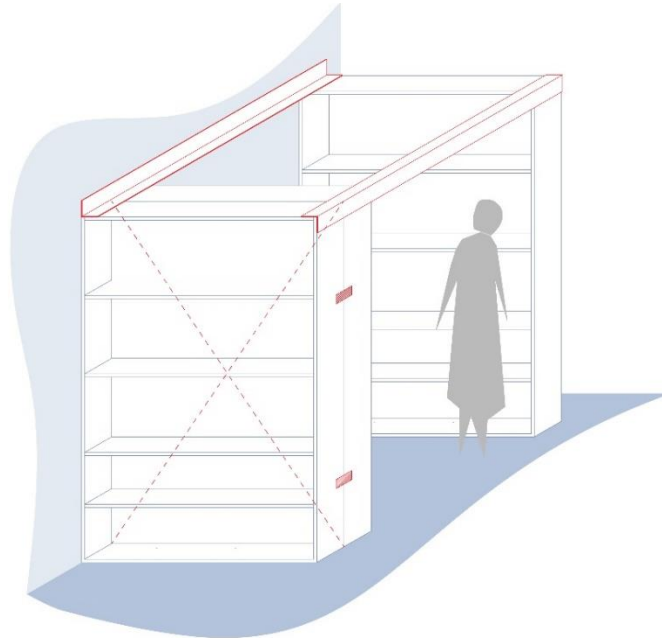





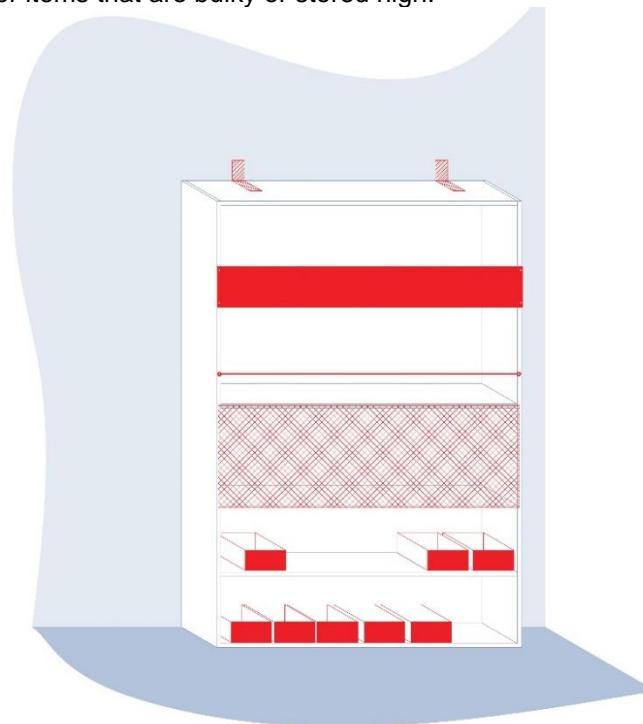

Adapted from [12, 31] by M. Vicente

Put heavier items on lower shelves and positive latches on cabinet doors. Use box restrains for individual bottles, and clear plastic lip screwed to shelf or removable lip folds down or lifts up. Use net restraints for items that are bulky or stored high.



Technical drawing by M. Vicente

## 7. Storage racks and contents

Stakeholder	Life safety	Property loss	Functional loss
			
Solution/ Expertise	Repair time	Costs of strengthen	
			

### Typical causes of damages

Rack components are made out of high-strength steel profiles. They are subject to general, local and also distortional buckling, especially in the uprights. Unsecured storage racks may fall, striking nearby occupants or blocking doors and exit ways for evacuation during an emergency.

Shelving that has not been bolted to the floor will typically tilt, spilling contents on the floor and blocking the passages at the very least. Direct damage to shelving, especially from buckling or deformation of shelving components, is also very common.

Contents falling from racks (such as pallets) due to either operational mishap or earthquake shaking can potentially injure or even kill persons in the aisles.

### Recommended methods

Prevention of shelving collapse is best achieved by strengthening shelving components to prevent buckling and bending, anchoring the racks to the floor and connecting the racks to the building frame, e.g., columns, walls or roof trusses.

Wire decking can be installed to prevent items from falling through.

Wire mesh or barriers can be used on the face and rear of the racks to prevent items from falling from the front or back side of the racks. Methods of securing merchandise shall include rails, fencing, netting, security doors, gates, cables, or the binding of items on a pallet into one unit by shrink-wrapping, metal or plastic banding, or by tying items together with a cord. Each of the suggested methods has a specific, useful application, but they are not universally applicable and the most appropriate method to use depends largely on the type of merchandise and the operating logistics behind the merchandise [8].

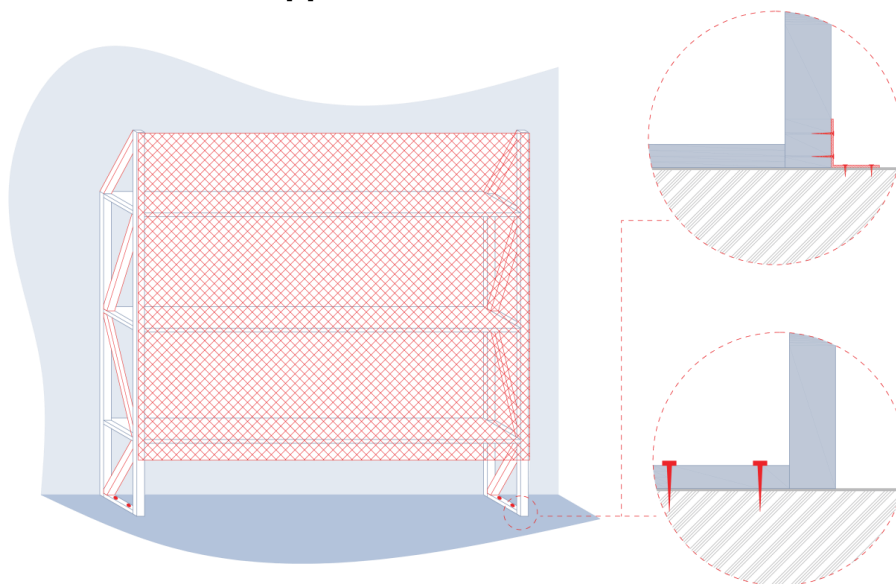

Adapted from [8, 30] by M. Vicente

Utilize rack safety netting when your load protrude no more than 10 cm past the back of the pallet rack beam.

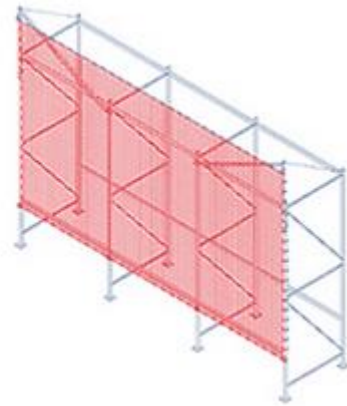
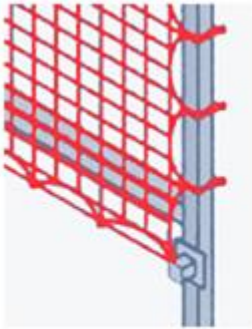



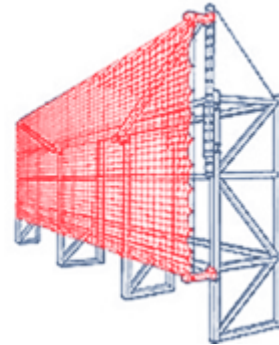
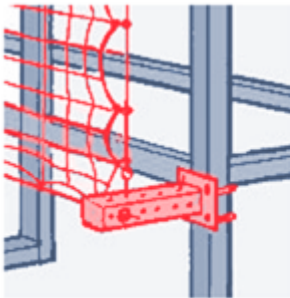



If your pallet overhangs the back of the rack by more than 10 cm, utilize offset mounting to accommodate the depth of the pallet.



Adapted from [30] by H. O'Neill

## 8. Tall file or storage cabinets for kitchen and office, and furniture

Stakeholder	Life safety	Property loss	Functional loss
			
Solution/ Expertise	Repair time	Costs of strengthen	
			

### Typical causes of damages

Unsecured refrigerator may slide or tip, striking nearby occupants or blocking doors and exit ways. Doors swinging open and drawers flying out can also cause unforeseen accidents. Broken tableware and other fallen objects can also block escape routes.

### Recommended methods

Secure furniture to walls using L-brackets. Secure all cabinets doors, especially those overhead, to help prevent contents from falling out during earthquakes. Cabinets must have push or child-proof latches.

The contents of cabinets may shift and break in the movement of an earthquake. To help prevent this movement, line your cabinets with rubberized shelf mats. This typically is sold in rolls or pre-cut squares at hardware and variety stores. To protect stacked china plates, place a square of this rubberized matting between each plate in the stack.

Do not place glassware and breakables on top of furniture. Store heavy items lower to the ground to keep them from falling.

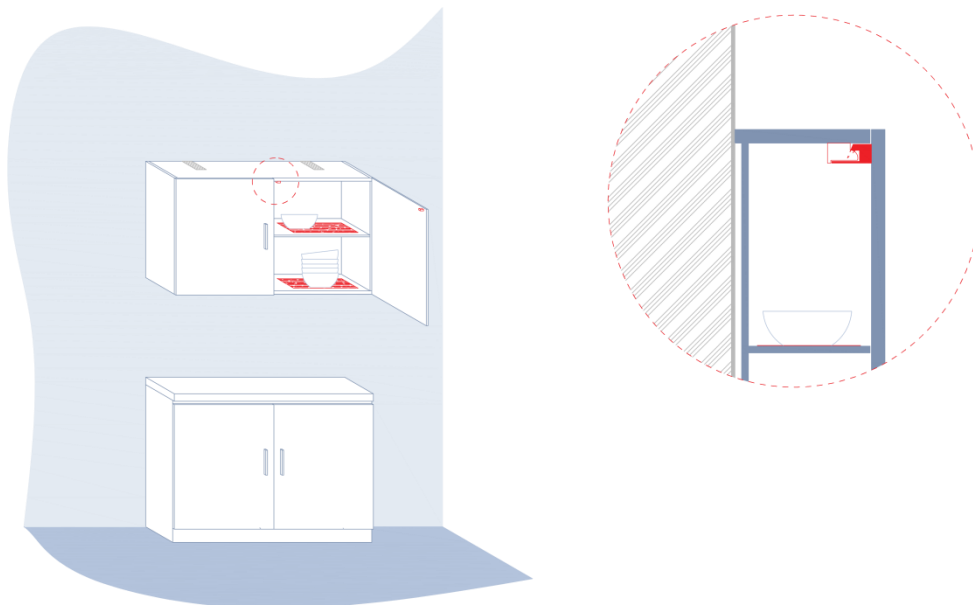





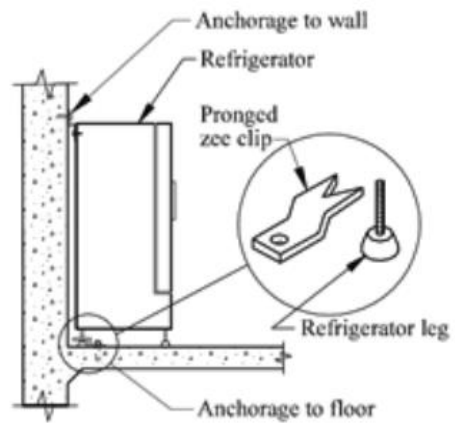

Technical drawing by M. Vicente

Secure refrigerators and other major appliances to walls or floor with slotted z-clips or clip angle.



Source: [12]

## 9. Fluorescent lighting fixture

Stakeholder	Life safety	Property loss	Functional loss
			
Solution/ Expertise	Repair time	Costs of strengthen	
			

### Typical causes of damages

The damage to lighting fixture is closely related with the method of installation. In some cases they failed because of weak stems or inadequate supports at the ceiling. Chain-hung fixtures fall because of failures in the chain or in the attachments to the supporting hooks at the ceiling. Plastic diffusers and side panels may drop from fluorescent fixtures during an earthquake, and grilles and globes may fall from incandescent fixtures, mainly because of insufficient retaining clips and poor design [36].

### Recommended methods

Brace ceiling-mounted lights with a diagonal wire at each corner to the structure above. Secure wire with three tight turns at each end.

Connect all suspended items to strong supports with safety cables capable of supporting each item's entire weight. Each cable should remain slack and not support the item's weight under normal circumstances.



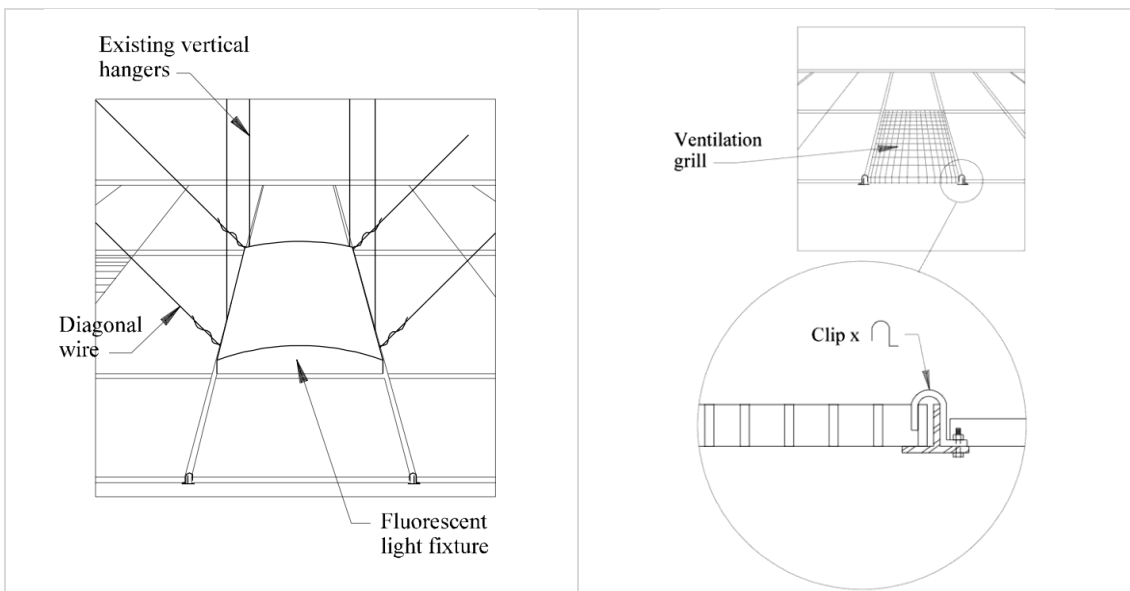

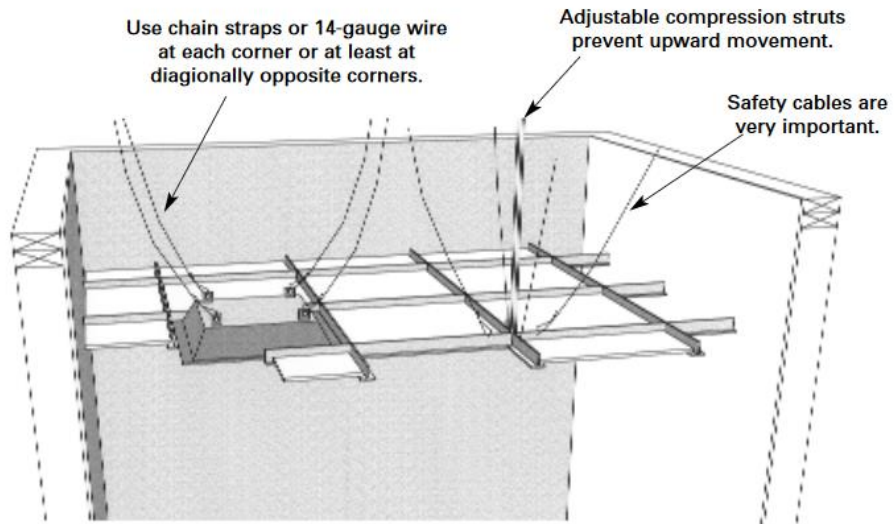

Use a chain strap or a minimum 14-gauge wire to attach the light fixture to a nearby ceiling support. Pay special attention to your home's fluorescent lights. Installing plastic sleeves over the fluorescent light tubes will keep the glass from scattering if they break. As an alternative, consider using Teflon® fluorescent lights, which are shatter-resistant [5, 36].





Sources: [5, 36]

## 10. Fragile artwork

Stakeholder	Life safety	Property loss	Functional loss
			
Solution/ Expertise	Repair time	Costs of strengthen	
			

### Typical causes of damages

Valuables or fragile items, collectibles and other loose objects can tip over and/or fall of shelves or pedestals.

### Recommended methods

Hold collectibles, pottery, and lamps in place by using removable earthquake putty, museum wax. Store heavy items and breakables on lower shelves.

Place object in close-fitting glass or plexiglass display case.

Store objects in padded trays (for example, use gator foam trays lined with ethafoam) or in individually-made holders or carved out shapes in 5 cm thick ethafoam.

The exhibition cases should either be secured to the floor. Put weights inside the objects (use small lead balls inside a double or triple cloth bag or sandbags) to lower the centre of gravity [37]

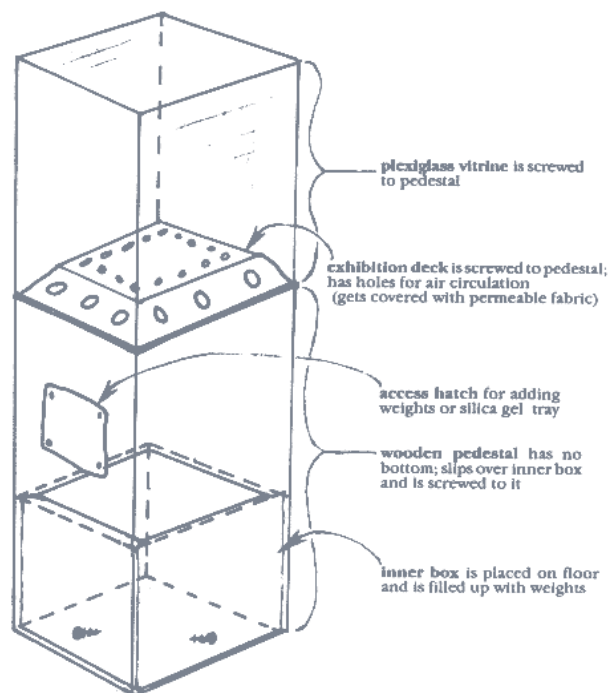



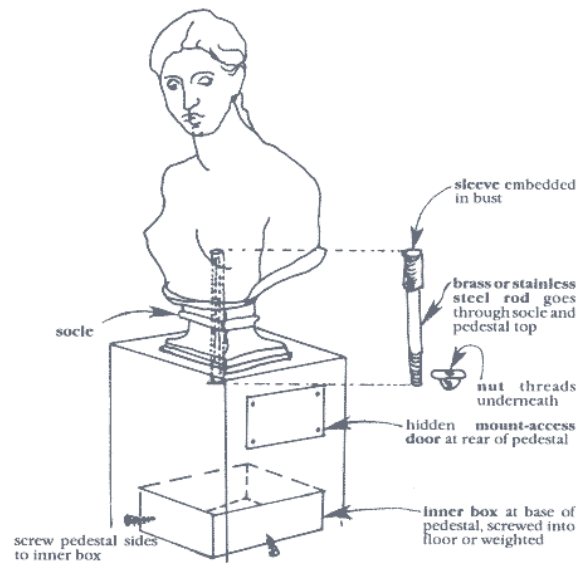



Large Sculptures and Objects Exhibited on Pedestals: secure the pedestal in a manner similar to that used for exhibition cases, but do not screw down onto the floor. It is important to counterweight the inside of the pedestal with weight equivalent to that of what is exhibited above- this will lower the centre of gravity. Mylar sheets, plexiglass or pieces of teflon can be applied to the corner bottoms of the pedestal. Tests have shown that the pedestals will slide around the floor if they are not screwed down, and that this is better for the art affixed to them.



Figures: [37]

## 11. Suspended ceiling

Stakeholder	Life safety	Property loss	Functional loss
			
Solution/ Expertise	Repair time	Costs of strengthen	
			

### Typical causes of damages

Significant damage during seismic events was caused by non-structural elements such as ceilings and in-ceiling services clashing. This was caused by insufficient clearance and/or stiffness incompatibilities.

### Recommended methods

Provide a suspension system strong enough to resist lateral forces imposed upon it without failing. Prevent border panels from falling from the ceiling plane.

The most common method of horizontal restraint is to fix the ceiling to the building structure on two sides of the perimeter. If perimeter fixing is not sufficient or appropriate, the ceiling may be back-braced by fixing to the structure above.

Ceiling areas greater than 200m<sup>2</sup> must have seismic separation joints, closure angles, and horizontal restraints.

A suspended ceiling must not be used to support plant or equipment that weighs more than 10 kg. Where a suspended ceiling is used to support equipment (cable trays, electrical conduits) it should be positively fixed to the ceiling suspension system, not supported by the ceiling panels or tiles.

All lighting fixtures that are mounted on a suspended ceiling, including detachable accessories (such as diffusers and light controllers), should use a positive locking mechanism to prevent them inadvertently disengaging during an earthquake.

### OPTION 1 | Perimeter fixing on adjacent edges

Ceiling is fixed to the perimeter on two adjacent sides and a seismic sliding joint is used on the opposite sides. Lateral loads are transferred from the ceiling to the perimeter through the perimeter fixing.

Fixed end with screw in front of slot. End of tee must be in contact with perimeter Wall Angle.

Floating end with screw in centre of slot and not tightened. 10mm gap between end of tee and perimeter Wall Angle.

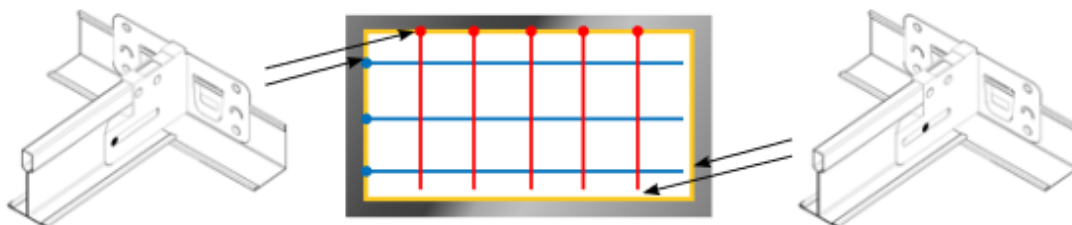

#### Legend

Main tee (fixed end)		Cross tee (fixed end)	
Main tee (free end)		Cross tee (free end)	
Perimeter trim		Surrounding Wall/Bulkhead	

### OPTION 2 | Perimeter fixing on more than two edges

The ceiling is split up into smaller sections using seismic joints. The ceiling can then be fixed to the perimeter on opposite sides. Lateral loads are transferred from the ceiling to the perimeter through perimeter fixings.

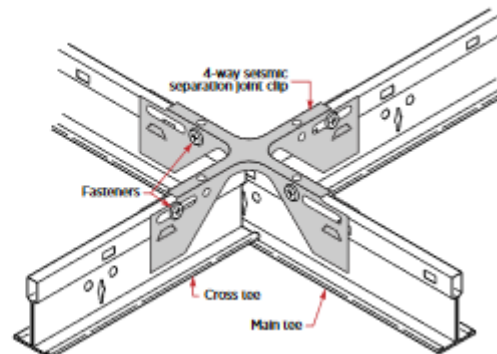

### OPTION 3 | Back bracing

The ceiling is braced back to the structure above with compression struts and tension wire braces or diagonal tension/compression struts. A seismic sliding joint around the entire perimeter is required, as the ceiling may not be braced to both the structure above and the perimeter.

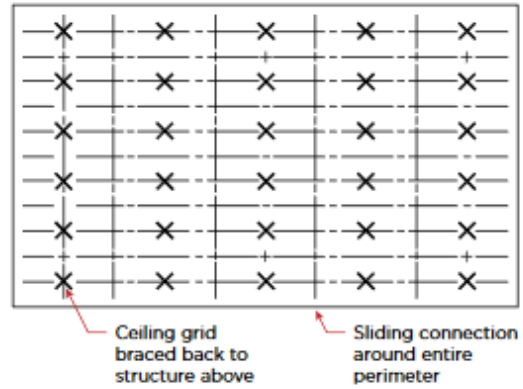

#### Steel Track (SS1 and SS3)



#### Steel Angle SA120 (SS2)

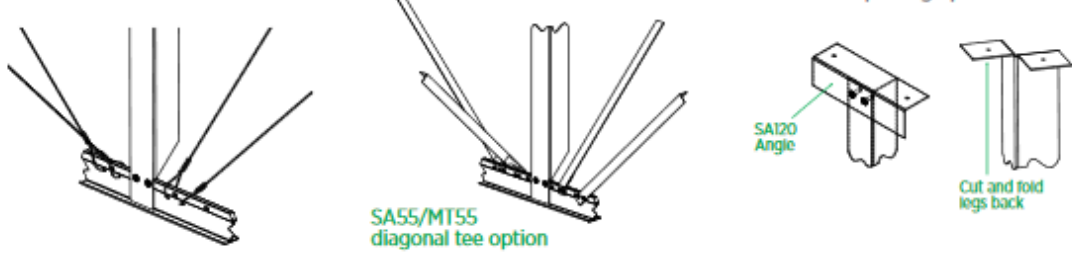



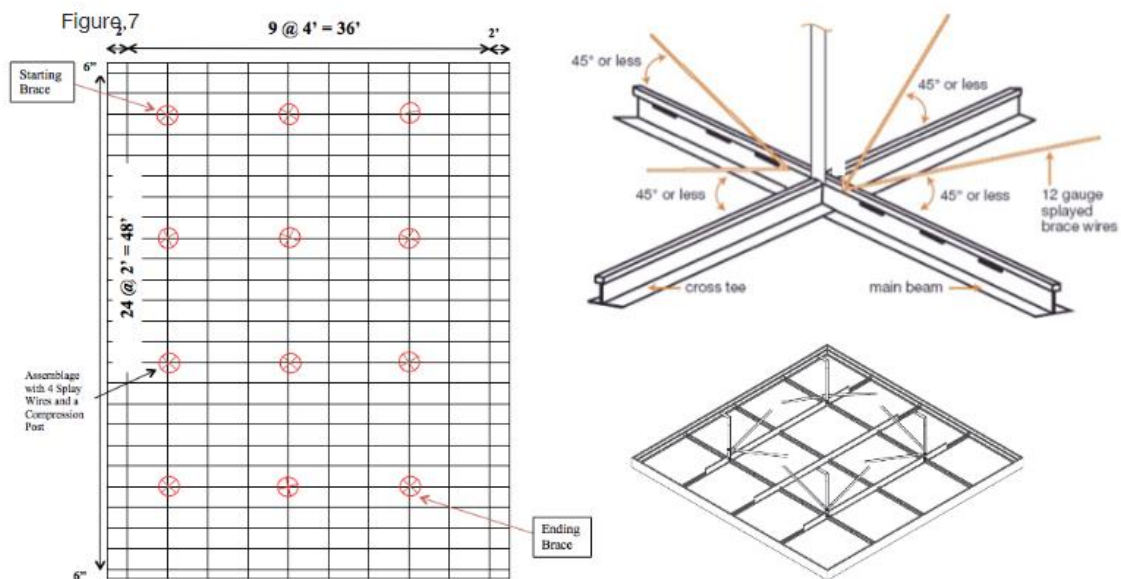



(Source: <https://www.usgboral.com/content/dam/USGBoral/Australia/Website/Documents/English/brochure-res-catalogues/USG%20Boral%20-%20Seismic%20Considerations%20Whitepaper.PDF>)



(Source: [http://www.soundconceptscan.com/docs/Seismic\\_0-2\\_Guidelines.pdf](http://www.soundconceptscan.com/docs/Seismic_0-2_Guidelines.pdf))

## 12. Desktop computer equipment, printers, copiers, scanner

Stakeholder	Life safety	Property loss	Functional loss
			
Solution/ Expertise	Repair time	Costs of strengthen	
			

### Typical causes of damages

Desktops, monitors, are tossed from desks, cracking screens and damaging hard drives.

### Recommended methods

Fix monitor to the wall or to the desk.

Wall-mounted TV or video monitors typically utilize a manufactured mounting bracket. The mounting bracket must be fastened to wall stud. TV or video monitors must be secured to the bracket. It's crucial that the wall or ceiling that you are mounting your television on is appropriate – some mounts are not manufactured to be mounted onto walls or ceilings with steel studs or cinder block construction.

Locate desktop computers and printers far enough from the edges of tables and desks to prevent them from sliding and falling in an earthquake. Non-slip rubber mat can be used to prevent movement.

If the TV or monitor is on a base or stand, these can be fastened using strap restraints.

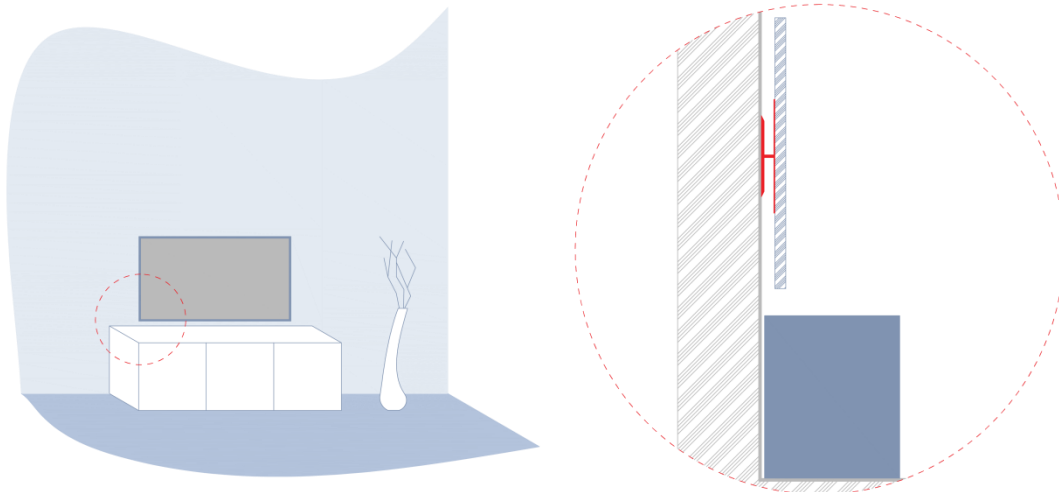





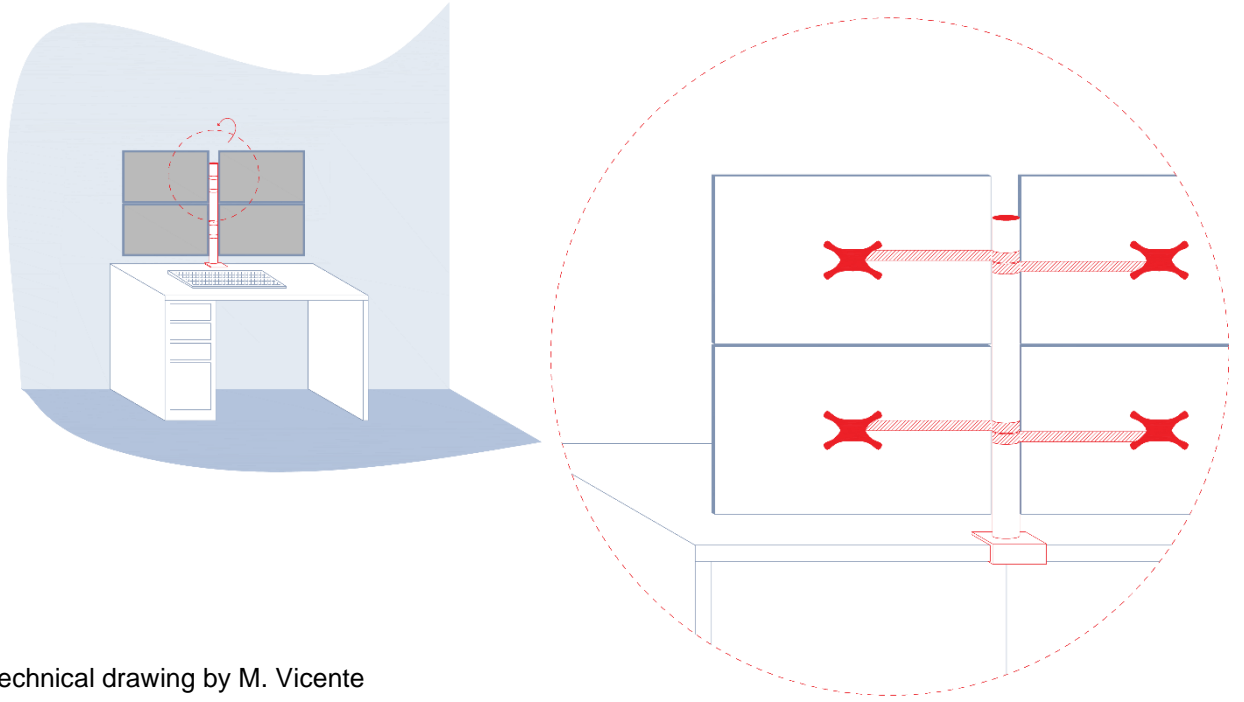

Technical drawing by M. Vicente

Secure electronic equipment to the floor or table surface with braces.



Technical drawing by M. Vicente

## 17. Concrete panels

Stakeholder	Life safety	Property loss	Functional loss
			
Solution/ Expertise	Repair time	Costs of strengthen	
			

### Typical causes of damages

The possibility of detachment of heavy concrete façade panels represents a severe threat to life safety.

### Recommended methods





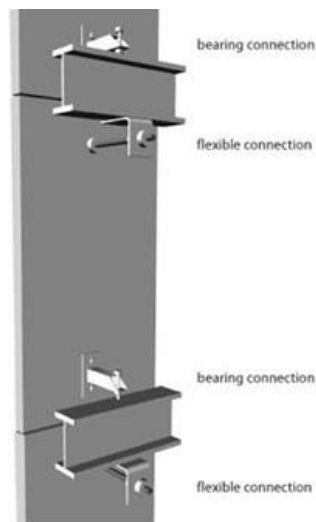

The design and installation of cladding systems needs great care because successful performance depends on solving problem of the interaction between cladding and building structure during a seismic event. Heavy cladding systems consist typically of precast concrete: they may also have additional attached facing materials such as natural stone or ceramic tile. Seismic codes require that heavy panels accommodate movement either by sliding or ductile connections.

The need for disassociating the heavy panel from the frame has a major impact on connection detailing. As a result, a connection commonly termed "push-pull" provides, if properly engineered and installed, a simple and reliable method of de-coupling the panel from the structure. The generic connection method consists of supporting the panel by fixed bearing connections to a structural element at one floor to accommodate the gravity loads, and using ductile "tie-back" connections to a structural element at an adjoining floor [38].



More information and solutions related with this subject may be found at [38]

## 19. Parapets, cornices, corbels and decorative elements

Stakeholder	Life safety	Property loss	Functional loss
			
Solution/ Expertise	Repair time	Costs of strengthen	
			

### Typical causes of damages

Parapets, decorative elements such as cornices and corbels or other architectural elements are common among historic, unreinforced masonry structures. Such elements are generally constructed of stone or other heavy, brittle materials, and often fail due to poor anchoring or bracing

### Recommended methods

Parapets can be braced from the rear using steel angle braces anchored into the parapet and connected to the roof framing. Parapets can also be braced using reinforced concrete or shotcrete placed behind the parapet and anchored. Reducing the height of parapets also reduces the seismic forces on the parapet by reducing the weight.

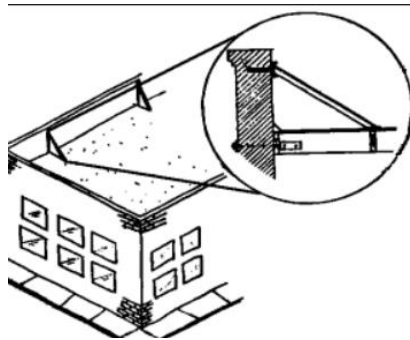





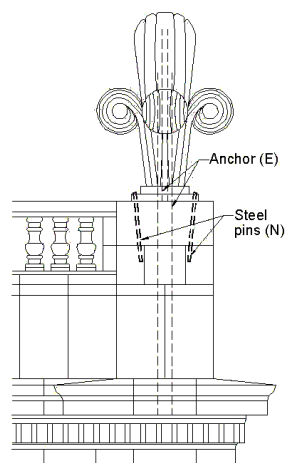

Source: [9]

Architectural building elements such as cornices, corbels, and spandrels can be anchored from the outside by installing anchors with exterior washer plates, or from the inside using either countersunk plates and/or epoxy anchors.



## 21. Compressed gas cylinders / Tanks / Bottles

Stakeholder	Life safety	Property loss	Functional loss
			
Solution/ Expertise	Repair time	Costs of strengthen	
			

### Typical causes of damages

Unsecured cylinders or tanks, including oxygen and compressed air tanks, may fall over and damage the shut-off valve, releasing hazardous or flammable contents. A tank with a damaged shut-off valve may result in the tank or valve becoming a projectile. Unsecured cylinders may fall over, striking or rolling and striking nearby occupants.





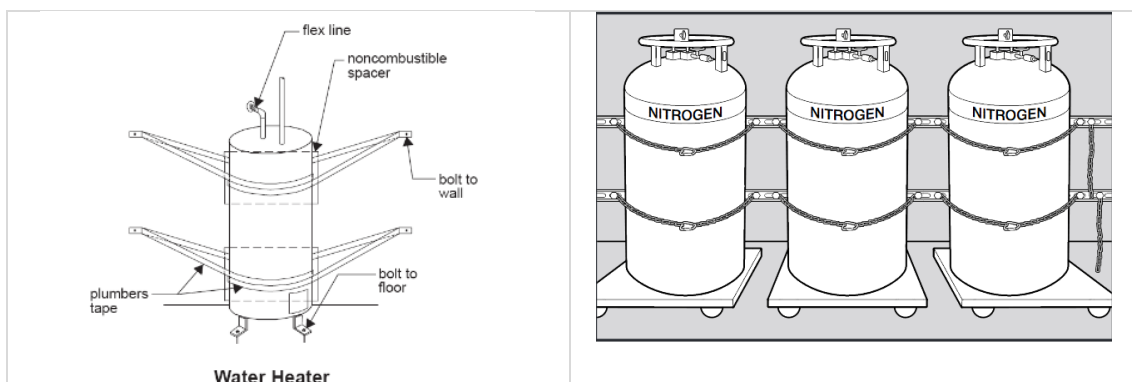
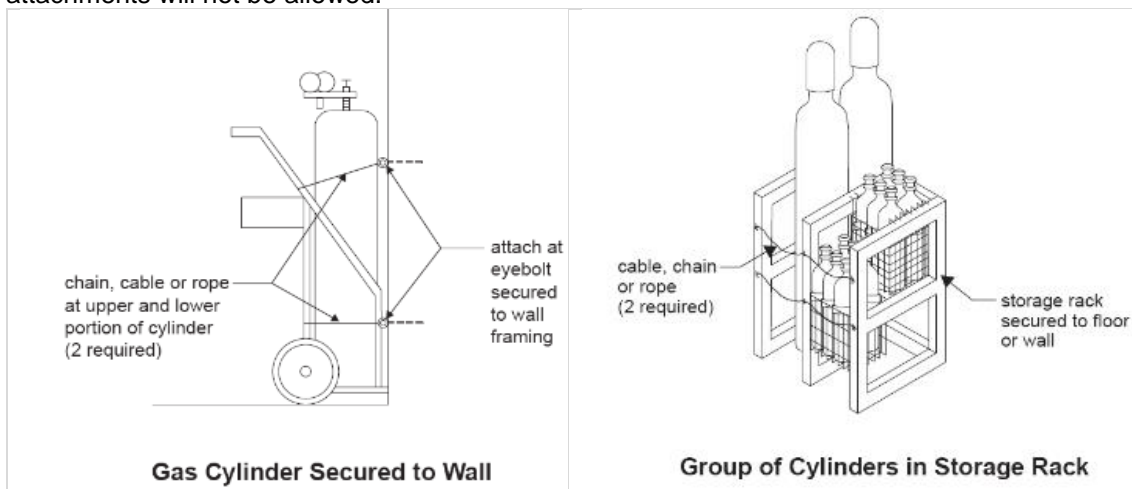

### Recommended methods

All compressed gas cylinders must be secured individually to a solid structural member with 4 mm welded chain or equivalent bracing. At least one chain must be used to secure each cylinder at a point two-thirds up the cylinder's height. C-clamp bench attachments and fiber/web strap attachments will not be allowed.



Source [28]

## 22. Raised access floors

Stakeholder	Life safety	Property loss	Functional loss
			
Solution/ Expertise	Repair time	Costs of strengthen	
			

### Typical causes of damages

Access floors (raised floor) may collapse if not adequately braced and anchored.

### Recommended methods

Raised floors are found in control rooms in electric power, water, gas, and transportation facilities, and in banks and insurance companies. The rapid expansion of Internet services accelerated the use of raised floors [23].

Raised floors must be capable of withstanding lateral loads. Equipment supported on the raised floors must have some lateral restraint between the equipment and the raised floor. Heavy equipment must be supported directly from the building floor. Some methods of restraining equipment on the raised floor allow for some lateral movement, so that equipment must be prevented from hitting each other or structural elements such as walls and columns.



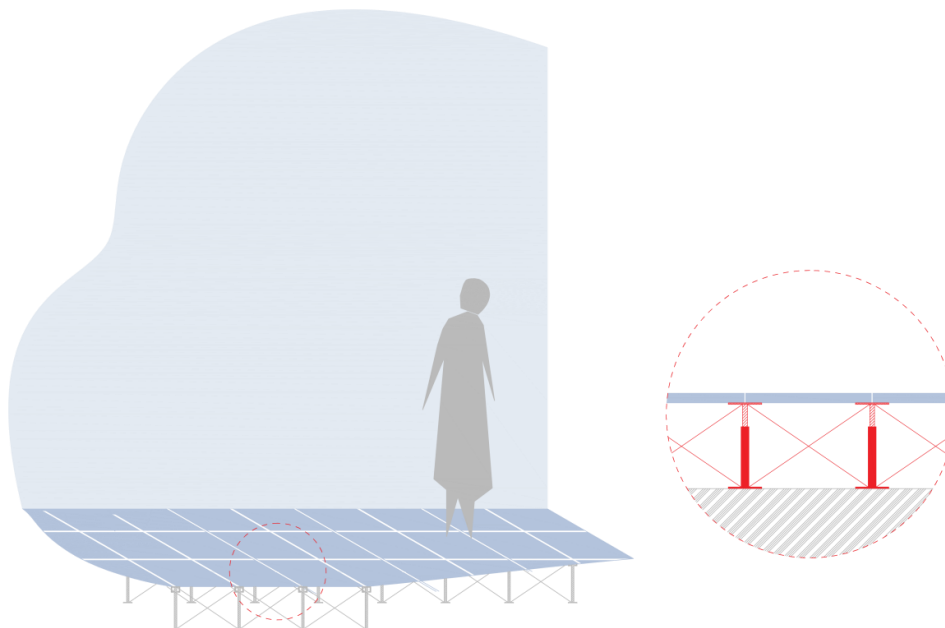



For high and moderate earthquake zones, the raised floor with the diagonal bracing is generally adequate for an office environment with lightweight equipment, such as desks, office partitions, printers and copiers. A more rigid system is required when the floor is used for critical equipment or in critical facilities. The number of diagonal braces should be one floor tile length around the perimeter of the equipment footprint. Pedestals should be anchored by bolting the base plate to the building floor and should be provided with supplemental bracing if needed.



Adapted from [23] by M. Vicente



## 24. Telecommunication antennae

Stakeholder	Life safety	Property loss	Functional loss
			
Solution/ Expertise	Repair time	Costs of strengthen	
			







### Typical causes of damages

Damage to the antennae could disable critical communications systems or television access that may be needed following an earthquake. Hospital communications depend on the functionality of antennae such as satellite dishes.

### Recommended methods

Antennas are usually installed on tall towers or on a tower on top of a tall building, and their response are influenced by the dynamic characteristics of the building. A study where the correlation between the building accelerations and the maximum seismic base shear as well as the base overturning moment of towers mounted on building rooftops can be found [39]. Large or tall antennae need to be properly engineered for both wind and seismic loading. Tower antennae may be anchored with guy wires, or mounted to a specially designed frame. Positive attachments from the antenna to the supporting structure should be provided and one should check with the manufacturer to see if the antenna has been designed or tested for seismic loading since seismic forces at the roof elevation are typically much higher than at ground level [7].

## 25. Elevators

Stakeholder	Life safety	Property loss	Functional loss
			
Solution/ Expertise	Repair time	Costs of strengthen	
			







### Typical causes of damages

Hydraulic elevators sustained minor damage, while damage to traction elevators are extensive. Damage to traction elevators included anchorage failures of motor-generator sets and control panels (control panels suffer little damage when anchored to the floor, but unanchored units toppled), and guiderail failures that allowed counterweights to obstruct the shafts.

### Recommended methods

Some seismic protective schemes can be used with rail-counterweight systems to reduce their seismic response. One protective measure [21] is the use of active tuned vibration absorbers. A tuned vibration absorber, can be easily configured in the existing system by utilizing a part of the counterweight mass as the mass of the absorber. The study shows that a tuned vibration absorber can be quite effective in reducing the seismic response. Professional engineering advice is recommended to ensure that appropriate solution is established.

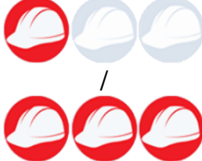
## 27. Glazing and windows

Stakeholder	Life safety	Property loss	Functional loss
			
Solution/ Expertise	Repair time	Costs of strengthen	
			

### Typical causes of damages

Windows and partitions are usually damaged because of the structural drift imposed upon these vertically oriented, rigidly built-in non-structural items.

### Recommended methods

Use of tempered glass will greatly reduce the seismic hazard. Tempered glass may still break, but will break into small dull fragments instead of large dangerous shards.

Polyester shatter resistant films (safety and security window films) help hold together fragments of any panes of glass in order to avoid injuries from flying glass. Typical solar film may not be adequate for this purpose.

Use of laminated glass for storefronts reduces seismic risk and also increases protection from vandalism. Blinds or even curtains can offer additional protection from shards of glass.





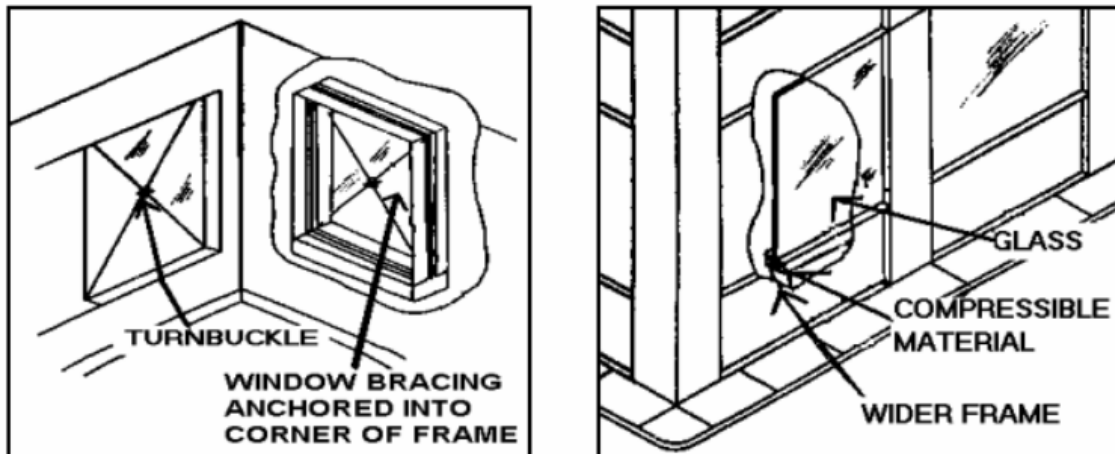

(Source: 3M™ Safety & Security Window Films)

Stiffening bracing or redesigning of the window frame can reduce earthquake damage from window frame distortion and inadequate edge clearance around the glass. Bracing usually consists of steel tie rods anchored to the corners of the window frame and connected by a turnbuckle (Figure, left side). Another method is to use specially designed windows that use wider frames and include a compressible material between the frame and the window glass to avoid direct contact between the window and the frame (Figure, right side).



Source: [9]

## 28. Chimneys

Stakeholder	Life safety	Property loss	Functional loss
			
Solution/ Expertise	Repair time	Costs of strengthen	
			

### Typical causes of damages

Chimneys are common non-structural features susceptible to earthquake damage, even in zones of low-to medium-seismic activity. In some cases, the entire chimney can peel away from the side of the home onto walkways below creating a life-safety hazard or crash through the roof.

### Recommended methods





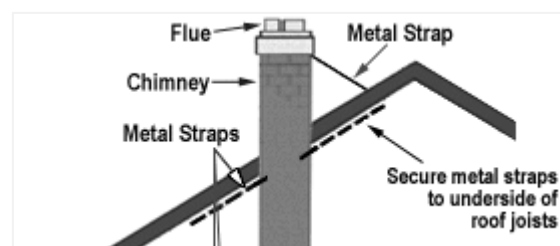
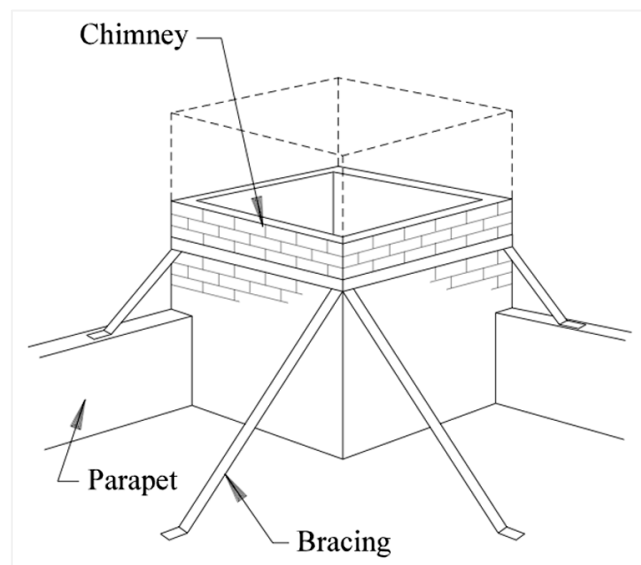

If the chimney comes out above your roof more than 1.5 m you are required to add a brace between the top portion of the chimney and the roof. Chimney can be secured with steel straps at several points to anchor the chimney to the home.

Replace the upper chimney with metal flues. The chimney flue enclosure can be reinforced using vertical and horizontal bars encased in concrete.



Source: [5]

## 29. Roof tiles

Stakeholder	Life safety	Property loss	Functional loss
			
Solution/ Expertise	Repair time	Costs of strengthen	
			

### Typical causes of damages

Clay or concrete tiles are heavy and are vulnerable to being displaced or dislodged unless they were sufficiently fixed to the frame of the building.

### Recommended methods

All tile roof claddings must be adequately fixed to the structure below to prevent them being displaced if the roof framing distorts under lateral loads (horizontal or sideways loads on the building) or if high vertical seismic accelerations occur.

At least every second tile (every tile is even better) should be fastened to the battens using wire or one or more metal clips, nails or screws. Some tiles use proprietary fixing systems, and it is important to use the correct type.





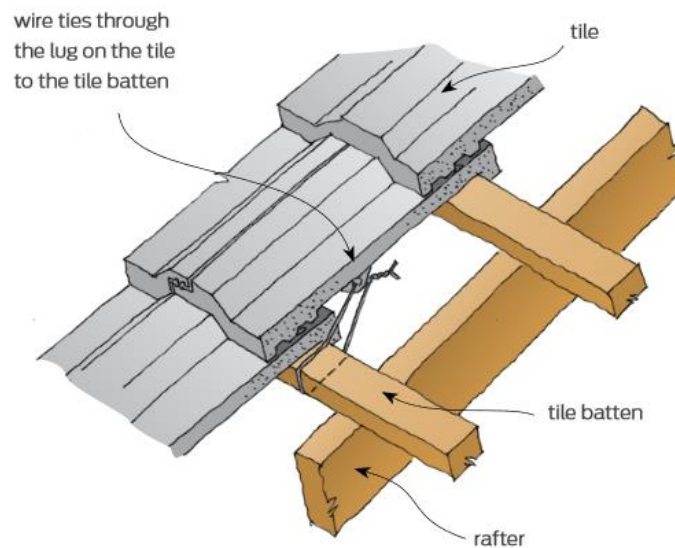

To remain effective, fixings must also be maintained and not allowed to become loose, rusted or broken. Replace damaged connecting ties with the same style of wire, clip, nail or screw.

If you live within 500 metres of the coast, use stainless steel fastenings so they don't rust [32, 33].



Source: [32, 33]

### 30. Modular partitions

Stakeholder	Life safety	Property loss	Functional loss
			
Solution/ Expertise	Repair time	Costs of strengthen	
			

#### Typical causes of damages

Unsecured modular partitions may collapse and cause serious damage overall.

#### Recommended methods

Arrange multiple partitions in a zigzag or T-shape fashion. Install angle braces at each end on each side of the partition with thru-bolts.



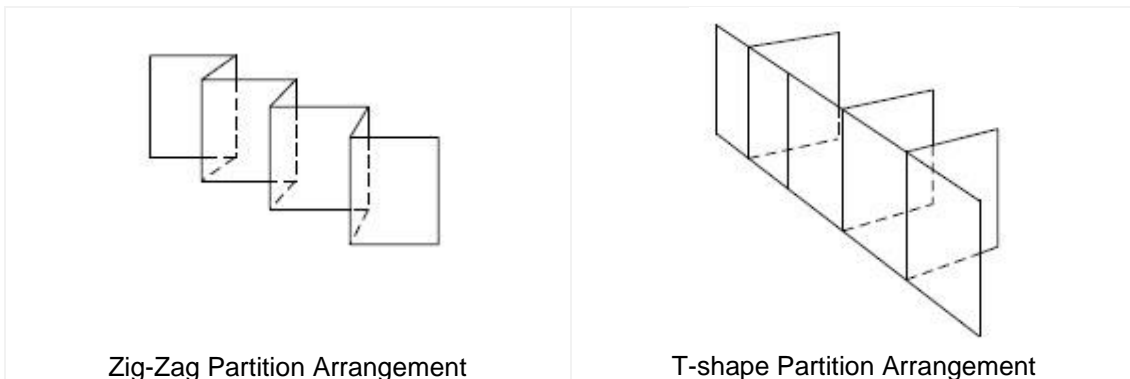

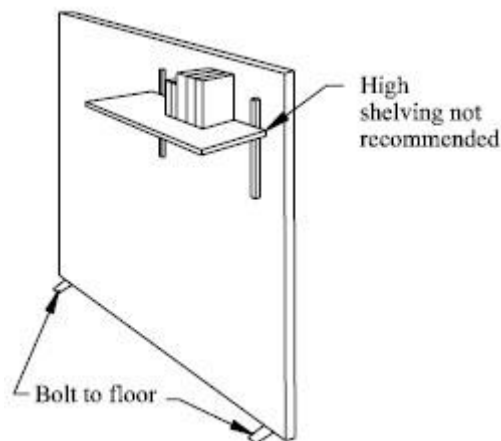

Attach the angles (or partition feet) to the floor with expansion bolts for concrete or lag bolts for wood or anchor the partition to the adjacent desk [5].



Install restraints to single modular partitions [5].



### 34. Hanging objects

Stakeholder	Life safety	Property loss	Functional loss
			
Solution/ Expertise	Repair time	Costs of strengthen	
			

#### Typical causes of damages

Art and other heavy objects hung on walls may fall, and glass in pictures and mirrors may shatter.

#### Recommended methods

Place only soft art, such as unframed posters or rugs and tapestries, above beds or sofas. Hang mirrors, pictures, and other hanging objects should utilize eye-hook connectors and except for light objects (less than 2, 5 kg) the supporting hardware must be connected to wall framing.



Figure from [14a].

Secure hanging items with slack cables. Provide space to swing freely, at least 45°.

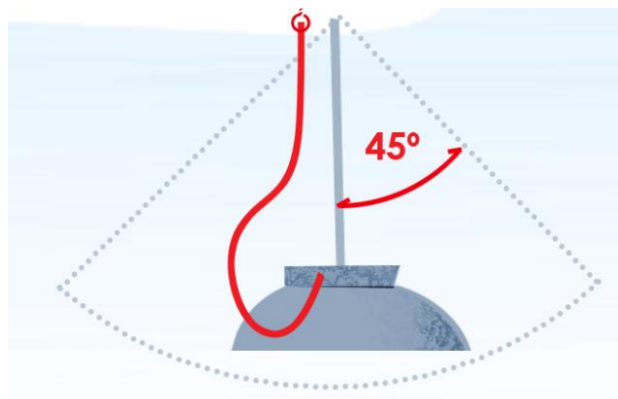









Figure from [14a].

### 36. Balconies

Stakeholder	Life safety	Property loss	Functional loss
			
Solution/ Expertise	Repair time	Costs of strengthen	
			







### Typical causes of damages

Stucco soffits on exterior surfaces, such as the underside of balconies or canopies, may fall if the wood or metal lath or finish materials are not adequately secured to the structure above or if the attachments have corroded or the components have deteriorated due to long term exposure or leakage from the roofing or decking above. Stucco soffits on cantilevered balconies or canopies may be particularly vulnerable as they often experience higher vertical accelerations than other structures.

### Recommended methods

Because balcony framing generally has a back span that extends into the interior of the house, adequate connection generally is not an issue; however, care should be taken to ensure that the back span is adequately fastened to the floor sheathing or to lapped floor framing and that blocking is provided where the cantilever bears on the exterior wall [42].

### 37. Electrical control panels, motor control centers, switchgear and substations

Stakeholder	Life safety	Property loss	Functional loss
			
Solution/ Expertise	Repair time	Costs of strengthen	
			

#### Typical causes of damages

Tall, narrow floor-mounted electrical items in sheet metal cabinets such as electrical control panels, motor control centers, switchgear, and substations can overturn or slide due to lack of anchorage or inadequate anchorage. Damaged electrical equipment may cause electrical hazards and fire hazards.

#### Recommended methods

Many of these components can be supplied with shop welded brackets or predrilled holes for base or wall anchorage. For additional base anchorage details refer to FEMA 413 Installing Seismic Restraints for electrical Equipment (2004) for general information on seismic anchorage of electrical equipment.









Equipment cabinets retrofitted with unidirectional snubbers at base



Cabinets tied together side by side using existing lifting hooks at top of cabinets

### 39. HVAC (Heating, ventilation, and air conditioning)

Stakeholder	Life safety	Property loss	Functional loss
			
Solution/ Expertise	Repair time	Costs of strengthen	
			







#### Typical causes of damages

Heating, ventilating, and air conditioning (HVAC) systems are essential building components that need to stay online immediately after a seismic event. This requirement is especially critical for essential services buildings such as data centres, hospitals, emergency shelters, such as schools or community centres.

#### Recommended methods

Suspended equipment should be braced to structural elements with sufficient capacity to resist the imposed loads. Do not brace to other equipment, ducts, or piping.  
Flexible connections should be provided for fuel lines and piping.  
Seismic isolation and damper devices provide protection for freestanding HVAC units. Base isolation protects equipment from vertical and horizontal seismic inputs.

#### 40. Vases and Flower pots (outside or indoors)

Stakeholder	Life safety	Property loss	Functional loss
			
Solution/ Expertise	Repair time	Costs of strengthen	
			

#### Typical causes of damages

Flower precariously rested on ledges, window sills or balconies can fall down causing serious injuries. Broken and toppled flower pots can present danger during emergency exits.

#### Recommended methods

Avoid putting plants on top of tall furniture. Move flower pots to a lower level. Flower pots can be anchored to surrounding surfaces to avoid damage and potential injury.

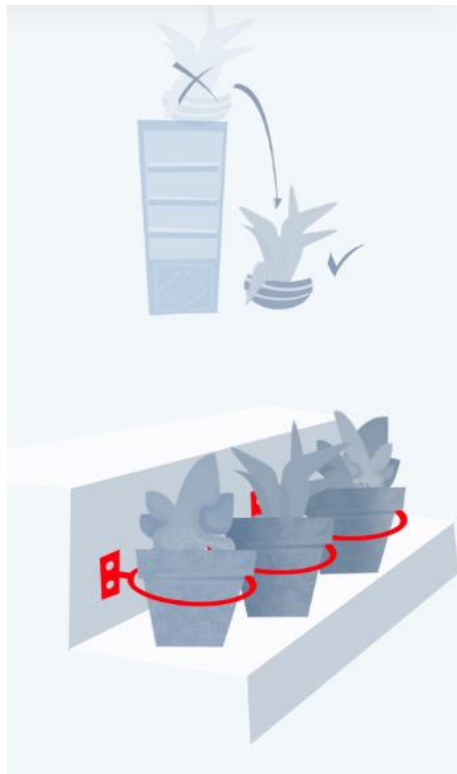

Figure from [14a].

## 5. Selected bibliography

- [1] Applied Technology Council (2017). Seismic Analysis, Design, and Installation of Nonstructural Components and Systems – Background and Recommendations for Future Work. U.S. Department of Commerce (<http://nvlpubs.nist.gov/nistpubs/gcr/2017/NIST.GCR.17-917-44.pdf>).
- [2] Armstrong seismic ceiling installation online catalog: <https://www.armstrongceilings.com/content/dam/armstrongceilings/commercial/north-america/brochures/seismic-design-what-you-need-to-know-brochure.pdf>
- [3] Chidiac, S.E.; Foo, S (2002). Guidelines for the seismic upgrading of stone-masonry structures. Chidiac & Associates Limited; Public Works & Government Services Canada. <https://doi.org/10.13140/2.1.1786.5767>.
- [4] Earthquake Commission (2012). Easy ways to quake safe your home. New Zealand (<http://www.eqc.govt.nz/fixfasten/guide>)
- [5] Earthquake Country Alliance (ECA). Southern California Earthquake Center. <https://www.earthquakecountry.org/>.
- [6] FEMA E-74 (2012). Reducing the Risks of Non-structural Earthquake Damage – A Practical Guide, Federal Emergency Management Agency (FEMA), Washington.
- [7] FEMA 74-FM (2005). Earthquake hazard mitigation for non-structural elements. Field Manual. Federal Emergency Management Agency (FEMA), Washington.
- [8] FEMA 460 (2005). Seismic considerations for steel storage racks located in areas accessible to the public. Federal Emergency Management Agency (FEMA), Washington.
- [9] FEMA (2004). Non-structural earthquake mitigation – Guidance Manual, Federal Emergency Management Agency (FEMA), Washington.
- [10] FEMA 74-FM (2005). Earthquake hazard mitigation for non-structural elements. Field Manual. Federal Emergency Management Agency (FEMA), Washington.
- [11] Filiatrault, A. and Sullivan, J.T. (2014). Performance-based seismic design of non-structural building components: The next frontier of earthquake engineering. Journal of Earthquake Engineering & Engineering Vibration.
- [12] Guide and Checklist for Non-structural Earthquake Hazards in California Schools (2011). California Department of General Services. California Emergency Management Agency.
- [13] Instor. Earthquake mitigation solutions. (<https://blog.instor.com/data-center-downloads>).
- [14] KnowRISK (Know your city, Reduce seismic risk through non-structural elements) (2016-2017) project. Co-financed by European Commission's Humanitarian Aid and Civil Protection Grant agreement ECHO/SUB/2015/718655/PREV28. ([www.knowriskproject.com](http://www.knowriskproject.com)).
- [14a] Ferreira, M.A.; O'Neill, H.; Solarino, S.; Musacchio, G. (2017). KnowRISK Practical Guide. KnowRISK (Know your city, Reduce seismic risk through non-structural elements) (2016-2017) project. Co-financed by European Commission's Humanitarian Aid and Civil Protection Grant agreement ECHO/SUB/2015/718655/PREV28.

- [15] Laboratory Seismic Restraints. UC San Diego labs. <https://blink.ucsd.edu/safety/research-lab/laboratory/lab-restraints.html>.
- [16] Murty et al., (2012) Introduction to Earthquake Protection of Non-Structural Elements in Buildings. Gujarat State Disaster Management Authority. Government of Gujarat. [http://www.iitk.ac.in/nicee/IITK-GSDMA/NSE\\_002\\_31May2013.pdf](http://www.iitk.ac.in/nicee/IITK-GSDMA/NSE_002_31May2013.pdf).
- [17] NZS 4219:2009. Seismic performance of engineering systems in buildings. Ministry of Business, Innovation, and Employment: Building Systems Performance. New Zealand.
- [18] Petal, M. (2003). "NSM Non-structural risk mitigation –Handbook". Istanbul: Disaster Preparedness Education Project (<http://www.koeri.boun.edu.tr/aheb/pdf%20dokumanlar/nsm%20education%20handbook.pdf>).
- [19] Sankaranarayanan, R. (2007). Seismic response of acceleration-sensitive non-structural components mounted on moment-resisting frame structures. PhD thesis, University of Maryland.
- [20] Selvaduray, G. (?) Non-structural hazard mitigation: Protecting people, property and your business. San José State University.
- [21] Singh, M.P.; Rildova (2004). Seismic Countermeasures for rail-counterweight system in elevators. Proceedings 13<sup>th</sup> World Conference on Earthquake Engineering. Vancouver, B.C., Canada, August 1-6, Paper No. 2825 ([http://www.iitk.ac.in/nicee/wcee/article/13\\_2825.pdf](http://www.iitk.ac.in/nicee/wcee/article/13_2825.pdf)).
- [22] SPONSE <http://www.sponse.eu/>
- [23] Tang A.K., Schiff, A.J. (?) Selection and installation of raised floors for critical facility equipment in seismic zones. National Information Centre of Earthquake Engineering at IIT Kanpur, INDIA [http://www.iitk.ac.in/nicee/wcee/article/14\\_S30-004.PDF](http://www.iitk.ac.in/nicee/wcee/article/14_S30-004.PDF)
- [24] D'Ayala, D.; Galasso, C.; Minas, S. and Novelli, V. (2015). Review of the non-structural considerations for seismically retrofitting hospitals, impact on hospital functionality, and hospital selection. DOI: [http://dx.doi.org/10.12774/eod\\_hd.june2015.ddayalaetal2](http://dx.doi.org/10.12774/eod_hd.june2015.ddayalaetal2).
- [25] Reduce earthquake damage to businesses <https://disastersafety.org/earthquake/reduce-earthquake-damage-to-businesses/>
- [26] <http://www.palletrackingcompany.co.uk/>
- [27] <http://www.ehs.ucsb.edu/labsafety/lab-seismic-hazard-reduction>
- [28] <http://homebuysblog.com/simi-valley-earthquake-preparedness-water-heater-bracing/>
- [29] <https://www.illinois.gov/iema/Preparedness/Pages/SchoolHuntImages>
- [30] <http://www.cisco-eagle.com/>
- [31] Non-structural earthquake protection manual for Idaho schools (1991). Idaho Department of education. Idaho Bureau of Disaster Services. [http://www.curee.org/organization/office/docs/1991\\_Nonstructural\\_EQ\\_Protection\\_Manual.pdf](http://www.curee.org/organization/office/docs/1991_Nonstructural_EQ_Protection_Manual.pdf)
- [32] <https://wellington.govt.nz/~media/services/rates-and-property/earthquake-prone-buildings/files/earthquake-strengthen-your-house.pdf>
- [33] <http://www.seismicresilience.org.nz/topics/building-envelope/residential-buildings/roof-claddings/>.

- [34] Risk topics. Natural hazards resilience: Seismic design & detailing of non-structural components (2015). Zurich Insurance Group Ltd.
- [35] The Great Alaska Earthquake of 1964 (1973). Committee on the Alaska Earthquake of the Division of Earth Sciences. National Research Council (U.S.). ISBN 0-309-01606-1.
- [36] A Homeowner's Guide to Earthquake Retrofit (1999). Institute for Business & Home Safety. ISBN 1-885312-22-9.
- [37] Cornu, E.; Bone, L. (1991). Seismic Disaster Planning: Preventive Measures Make a Difference. Western Association of Art Conservation (WAAC) Newsletter, Volume 13, Number 3, pp.13-19.
- [38] Whole Building Design Guide. <https://www.wbdg.org/resources/seismic-safety-building-envelope>.
- [39] McClure G; Georgi, L; Assi, R. (2004). Seismic considerations for telecommunication towers mounted on building rooftops. Proceedings 13<sup>th</sup> World Conference on Earthquake Engineering, 1-6 August, Vancouver, B.C., Canada.
- [40] FEMA-445 (2006). Next-Generation Performance-Based Seismic Design Guidelines Program Plan for New and Existing Buildings / August 2006 FEMA nehrp <https://www.fema.gov/media-library-data/20130726-1600-20490-1237/fema445.pdf>
- [41] SHARE (2003). European Seismological Commission <https://www.preventionweb.net/english/professional/maps/v.php?id=44281>
- [42] FEMA-232 (2006). Homebuilders' Guide to Earthquake-Resistant Design and Construction. <https://www.wbdg.org/FFC/DHS/fema232.pdf>



Copyright © 2017



**TÉCNICO**  
LISBOA



**Istituto Nazionale di**  
**Geofisica e Vulcanologia**



**LABORATÓRIO NACIONAL**  
**DE ENGENHARIA CIVIL**



**EARTHQUAKE ENGINEERING RESEARCH CENTRE**  
**UNIVERSITY OF ICELAND**



Co-financed by European  
Commission's Humanitarian Aid and  
Civil Protection Grant agreement  
ECHO/SUB/2015/718655/PREV28

**CERIS** : Civil Engineering Research  
and Innovation for  
Sustainability



CERIS - Civil Engineering Research and Innovation for Sustainability

Address: Av. Rovisco Pais, 1, 1049-001 Lisboa-Portugal

E-mail: [ceris@tecnico.ulisboa.pt](mailto:ceris@tecnico.ulisboa.pt)

Tel.: (+351) 218 418 238

[www.ceris.pt](http://www.ceris.pt)

