

Fire risk analysis applied to buildings of historical value in Brazil

Summary

Fire is defined as fire that gets out of control, causing danger and damage to people and property. The risk of a fire happening cannot be eliminated since there is no such thing as a completely safe or zero-risk building. However, it is possible to prevent this event and its consequences by reducing the chances of ignition, making it difficult for the fire to spread inside the building or mitigating the damage caused by the fire. In Brazil, although there has been a great deal of commotion in the face of major tragedies caused by fires, prevention against these events is still mostly carried out in a compulsory manner, through state legislation that determines the minimum safety standards for buildings. When we add buildings of historical value to this context, the difficulties increase. This is because these buildings were built when there were no fire safety rules established for architectural projects; and possible alterations to the structure are limited by listing laws and the protection of their historical value.

There are various fire risk analysis methods that are applied in different contexts around the world. In this study, five semi-quantitative analysis methods were used - the Gretener Method, the FRAME Method, the MARIEE Method, the Global Fire Risk Method and the ARICA Method. The methods were applied considering all the guidelines in the respective user manuals and the state fire safety legislation to which each building was subject. In total, six buildings of historical value in four Brazilian states were analysed.

The application of fire risk analysis methods to buildings of historical value showed that the safety parameters considered by these methods conflict with the safety parameters in the Brazilian legislation, which meant that the results varied depending on the fire safety legislation applied. There was also a divergence between the final results of the methods for the same building. In view of this, a proposal has been drawn up for a new fire risk analysis method, called Cálculo Escalonar de Perigo de Incêndio – CEPI, which judges safety parameters based on expert analysis, offering five different analysis perspectives, and aims to eliminate the interference of legislative differences in analysing the fire danger in buildings.

Keywords

Fire risk analysis, fire safety, buildings of historical value.

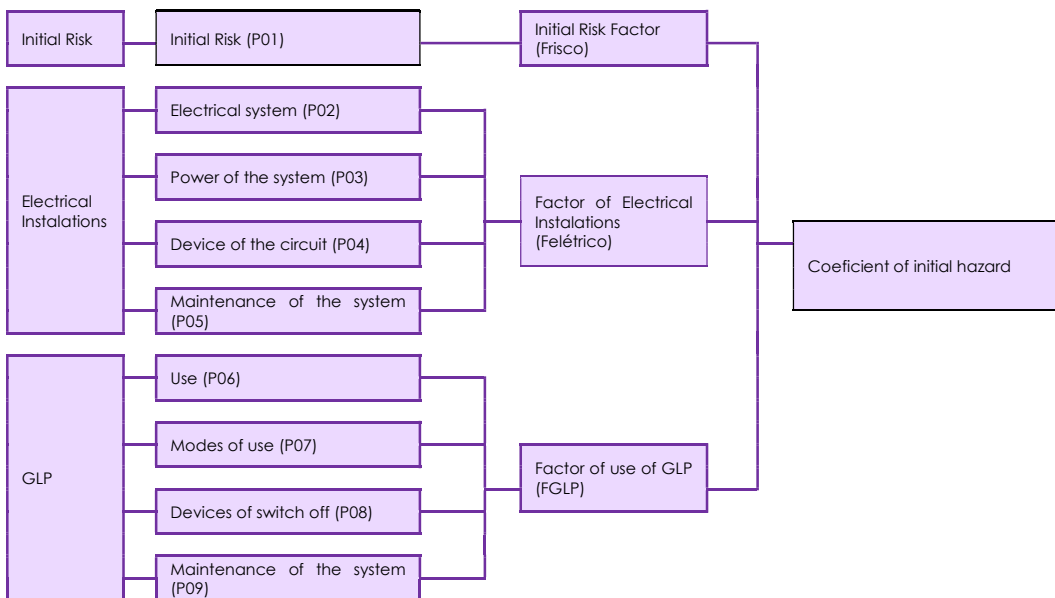

Resume of the parameter's relation for the calculation of the Initial Hazard Coefficient of CEPI methodology.



PhD student

Bernardete de Lourdes Ferreira Minervino

PhD program

Fire Safety Engineering (FCT, University of Coimbra)

Supervisor

Cristina Calmeiro dos Santos (FCT, University of Coimbra)

Co-supervisors

João Paulo Rodrigues (FCT, University of Coimbra; CERIS, IST, University of Lisbon) and Paulo von Krüger (UFMG, Federal University of Minas Gerais)

Period

2018-2024

Funding

-